

# FO Series Power On Clutch Couplings

## Mounting Instructions

P-8158-IDI  
040-10244

Figure 1

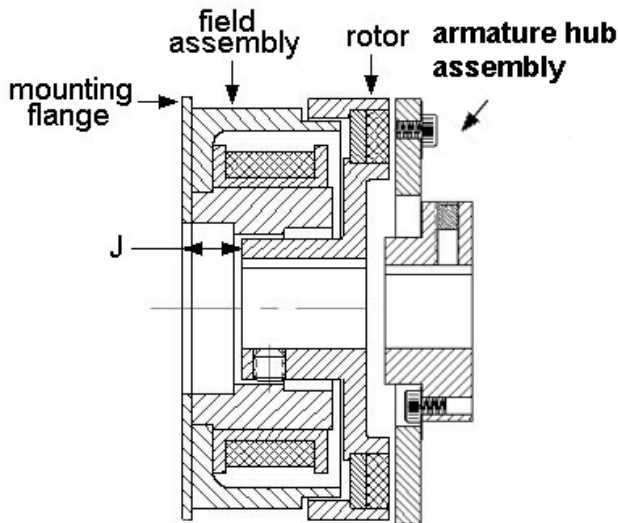

FO series power-on clutches are used to couple two inline shafts. The field assembly is mounted to a bulkhead that is perpendicular to the clutch shaft and then the rotor is assembled to the shaft. Typical FO clutch installations provide a coupling between the drive and the driven shaft.

1. Examine parts for damage from shipping and handling. Measurements should be taken to ensure parts meet application requirements. All parts must be clean and free of any foreign material before attempting assembly.

**Note:** Do not hi-pot clutches with AC operating voltages as that will damage the internal rectifier.

2. The two in-line shafts must be concentric to each other within 0.005" (0.13mm) total indicated reading (T.I.R.). Angular alignment must be within 0.5 degrees.
3. Install keys in respective shafts. Keys should fit keyseat with a tight fit on the sides and slight clearance over the key.

4. Slide the rotor onto the shaft. Position the rotor/shaft assembly into support bearings. Retain the shaft axially. Position the rotor on the shaft per dimension "J" (see chart 1) (FO-08 & FO-11 have cross pin versus set screw.) Remove the rotor/shaft assembly from the bearings.

Chart 1

### Imperial

Unit Size	Dim J (in)
08	.015/.025
11	.015/.025
15	.095/.105
17	.095/.105
19	.095/.105
22	.095/.105
26	.370/.380
30	.142/.152
42	.185/.195

### Metric

Unit Size	Dim J (mm)
08	.381/.635
11	.381/.635
15	2.413/2.667
17	2.413/2.667
19	2.413/2.667
22	2.413/2.667
26	9.40/9.65
30	3.607/3.861
42	4.699/4.953

5. Utilizing the inside pilot diameter in the square mounting flange, mount the field assembly to the bulkhead (models FO-17 and larger have an inside & outside pilot diameter). Concentricity between the field assembly mounting pilot diameter and the shaft must be held to .010 inches (0.25mm) T.I.R.
6. Slide the armature hub assembly onto the shaft. Position the shafts and assemblies to achieve a normal operating air gap of .005" to .020" (0.13 to 0.51mm). Tighten the set screws in the hub to the recommended torque (see chart 2).
7. Wire the two leads or screw terminals to the power supply. Inertia Dynamics power supplies are available with a wiring diagram showing the proper electrical connections.

**Note:** After the unit has operated for a short period to time, recheck the air gap, set screws, etc.

Chart 2

Imperial

Set Screw Size	Recommended Tightening Torque
#4	5 in-lbs.
#5	9.5 in-lbs.
#6	9.5 in-lbs.
#8	19.4 in-lbs.
#10	33.5 in-lbs.
1/4"	78.0 in-lbs.

Metric

Set Screw Size	Recommended Tightening Torque
M3	1.13 Nm
M4	2.67 Nm
M5	5.31 Nm
M6	9.10 Nm

**Burnishing Procedure**

FO clutches are not pre-burnished and require a “run-in” period to develop rated torque— see burnishing procedure. Burnishing is a wearing-in or mating process to insure that the highest possible output torque will be obtained from the clutch. For consistent engagement and full rated torque, it may be necessary to burnish the clutch. Use the following procedures to properly burnish clutches. Do not prolong burnish beyond three-minute duration. Long burnish time will cause excessive heat build-up at the friction faces, resulting in poor performance. Care must be taken to prevent contamination of the friction faces with oil or dirt particles during the burnishing process. If possible, burnish units in their final application or location to ensure alignment of mated parts. If units cannot be burnished in final application, mount units in a test stand observing concentricity, alignment and air gaps. If clutch is required to accelerate a large inertia load, the normal slip that will occur when the load is engaged is frequently sufficient to cause the unit to become burnished. Inertia Dynamics’

clutches typically will produce 50-90% of their rated torque “out-of-box” without burnishing. Customer should determine if “out-of-box” torque is adequate for application as torque will automatically improve with normal cycling (especially on high speed, high inertia load applications).

1. Using a filtered DC power supply energize the clutch at 100% rated voltage for five seconds to assure proper armature engagement).
2. Reduce voltage to 30% to 40% of rated voltage. Rotate one member of the clutch (see chart 3 for suggested RPM) while holding the other member stationary. De-energize the unit after a three minute forced slip.
3. Measure the static/break away torque at rated voltage applied at zero RPM. Static torque of standard clutches after burnishing should be at catalog rating. Repeat burnishing procedure after a cool down period of five minutes if required.

Chart 3

Unit Size	Slip RPM +/- 10%	Imperial Standard Static Torque Rating	Metric Standard Static Torque Rating
8	250	2.5 in-lbs.	0.28 Nm
11	250	6 in-lbs.	0.68 Nm
15	190	10 in-lbs.	1.13 Nm
17	160	15 in-lbs.	1.70 Nm
19	150	25 in-lbs.	2.83 Nm
22	130	50 in-lbs.	5.65 Nm
26	60	80 in-lbs.	9.04 Nm
30	50	125 in-lbs.	14.12 Nm
42	30	250 in-lbs.	28.24 Nm

**⚠ WARNING** Because of the possible danger to person(s) or property from accidents, which may result from the improper use of products, it is important that correct procedures be followed: Products must be used in accordance with the engineering information specified in the catalog. Proper installation, maintenance and operation procedures must be observed. The instructions in the instruction manuals must be followed. Inspections should be made as necessary to assure safe operation under prevailing conditions. Proper guards and other suitable safety devices or procedures as may be desirable or as may be specified in safety codes should be provided, and are neither provided by Inertia Dynamics nor are the responsibility of Inertia Dynamics.



www.idicb.com

31 Industrial Park Road  
 New Hartford, CT 06057  
 860-379-1252  
 Fax: 800-379-1137