

Motor Brakes

AC Motor Brakes - Nema 4 Housing



AC MOTOR BRAKES

56,200 Nema 4 Housing

Factory Assembled and Tested
 Manual Release
 AC Power Off
 Rear Mounted
 Cast Iron Head
 Cast Iron Cover
 Includes O-Ring Seals to create a dust-tight brake enclosure

F Series

3 Ft-Lb
 6 Ft-Lb
 10 Ft-Lb
 15 Ft-Lb

AC Rear Mounted Brake

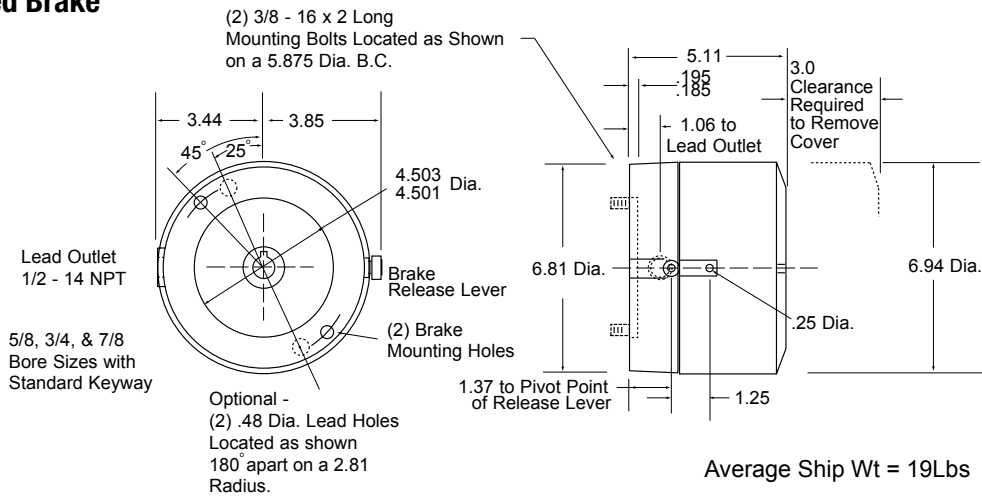

Brake Part Numbers

COIL VOLTAGE	5/8 BORE HUB			
	3 FT. LB. BRAKES	6 FT. LB. BRAKES	10 FT. LB. BRAKES	15 FT. LB. BRAKES
115/230, 60HZ	F51A1311	F52A1611	F52A1711	F53A1811
230/460, 60 HZ	F51A1314	F52A1614	F52A1714	F53A1814
287/575, 60 HZ	F51A1315	F52A1615	F52A1715	F53A1815
115/230, 50HZ	F51A1318	F52A1618	F52A1718	F53A1818
230/460, 50 HZ	F51A1319	F52A1619	F52A1719	F53A1819

COIL VOLTAGE	3/4 BORE HUB			
	3 FT. LB. BRAKES	6 FT. LB. BRAKES	10 FT. LB. BRAKES	15 FT. LB. BRAKES
115/230, 60HZ	F51B1311	F52B1611	F52B1711	F53B1811
230/460, 60 HZ	F51B1314	F52B1614	F52B1714	F53B1814
287/575, 60 HZ	F51B1315	F52B1615	F52B1715	F53B1815
115/230, 50HZ	F51B1318	F52B1618	F52B1718	F53B1818
230/460, 50 HZ	F51B1319	F52B1619	F52B1719	F53B1819

COIL VOLTAGE	7/8 BORE HUB			
	3 FT. LB. BRAKES	6 FT. LB. BRAKES	10 FT. LB. BRAKES	15 FT. LB. BRAKES
115/230, 60HZ	F51C1311	F52C1611	F52C1711	F53C1811
230/460, 60 HZ	F51C1314	F52C1614	F52C1714	F53C1814
287/575, 60 HZ	F51C1315	F52C1615	F52C1715	F53C1815
115/230, 50HZ	F51C1318	F52C1618	F52C1718	F53C1818
230/460, 50 HZ	F51C1319	F52C1619	F52C1719	F53C1819

Technical Data

60 HZ BRAKE COILS SINGLE PHASE			50HZ BRAKE COILS SINGLE PHASE			STATIC TORQUE FT. LB.	NUMBER DISCS
VOLTAGE	CURRENT HOLDING AMPS	CURRENT INRUSH AMPS	VOLTAGE	CURRENT HOLDING AMPS	CURRENT INRUSH AMPS		
115/230	.50/.25	3.66/1.83	115/230	.45/.22	3.27/1.64	3	1
230/460	.28/.14	1.94/.97	230/460	.24/.12	1.76/.88	6	2
287/575	.22/.11	1.54/.77				10	2
						15	3

AC Motor Brakes - Nema 2 Housing



AC MOTOR BRAKES

56,000 Nema 2 Housing

F Series

- | | |
|------------------------------|----------|
| Factory Assembled and Tested | 3 Ft-Lb |
| Manual Release | 6 Ft-Lb |
| AC Power Off | 10 Ft-Lb |
| Rear Mounted | 15 Ft-Lb |
| Cast Iron Head | |
| Cast Iron Cover | |

AC Rear Mounted Brake

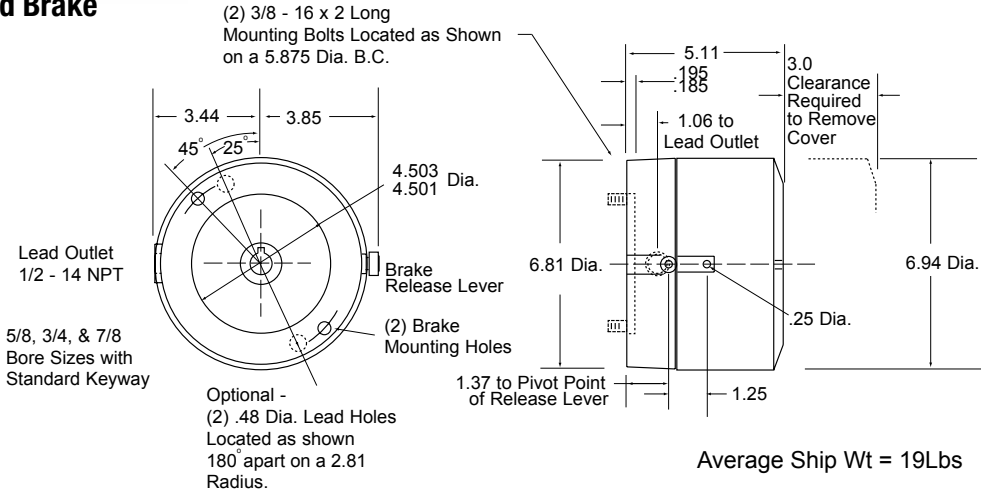

Brake Part Numbers

COIL VOLTAGE	5/8 BORE HUB			
	3 FT. LB. BRAKES	6 FT. LB. BRAKES	10 FT. LB. BRAKES	15 FT. LB. BRAKES
115/230, 60HZ	F51A8311	F52A8611	F52A8711	F53A8811
230/460, 60 HZ	F51A8314	F52A8614	F52A8714	F53A8814
287/575, 60 HZ	F51A8315	F52A8615	F52A8715	F53A8815
115/230, 50HZ	F51A8318	F52A8618	F52A8718	F53A8818
230/460, 50 HZ	F51A8319	F52A8619	F52A8719	F53A8819

COIL VOLTAGE	3/4 BORE HUB			
	3 FT. LB. BRAKES	6 FT. LB. BRAKES	10 FT. LB. BRAKES	15 FT. LB. BRAKES
115/230, 60HZ	F51B8311	F52B8611	F52B8711	F53B8811
230/460, 60 HZ	F51B8314	F52B8614	F52B8714	F53B8814
287/575, 60 HZ	F51B8315	F52B8615	F52B8715	F53B8815
115/230, 50HZ	F51B8318	F52B8618	F52B8718	F53B8818
230/460, 50 HZ	F51B8319	F52B8619	F52B8719	F53B8819

COIL VOLTAGE	7/8 BORE HUB			
	3 FT. LB. BRAKES	6 FT. LB. BRAKES	10 FT. LB. BRAKES	15 FT. LB. BRAKES
115/230, 60HZ	F51C8311	F52C8611	F52C8711	F53C8811
230/460, 60 HZ	F51C8314	F52C8614	F52C8714	F53C8814
287/575, 60 HZ	F51C8315	F52C8615	F52C8715	F53C8815
115/230, 50HZ	F51C8318	F52C8618	F52C8718	F53C8818
230/460, 50 HZ	F51C8319	F52C8619	F52C8719	F53C8819

Technical Data

60 HZ BRAKE COILS SINGLE PHASE			50HZ BRAKE COILS SINGLE PHASE			STATIC TORQUE FT. LB.	NUMBER DISCS
VOLTAGE	CURRENT HOLDING AMPS	CURRENT INRUSH AMPS	VOLTAGE	CURRENT HOLDING AMPS	CURRENT INRUSH AMPS		
115/230	.50/.25	3.66/1.83	115/230	.45/.22	3.27/1.64	3	1
230/460	.28/.14	1.94/.97	230/460	.24/.12	1.76/.88	6	2
287/575	.22/.11	1.54/.77				10	2
						15	3