

# Spring Applied Friction Brakes

## Reverse Mounted Spring Applied Brakes – Type FSBR Imperial



FSBR007 Shown

### FSBR SERIES SPRING APPLIED BRAKES

#### Reverse Mounted Spring Applied Brakes – Type FSBR

Inertia Dynamics type FSBR brakes are designed for applications requiring minimum space (short axial length) or for motors with short shaft extensions. When mounted, the hub is installed on the shaft first, then the brake is installed over the hub and attached to the motor.

#### Customer Shall Maintain:

The perpendicularity of the mounting surface with respect to the shaft not to exceed .005 inch T.I.R. at a diameter equal to the brake body outside diameter; the concentricity between the mounting holes and the shaft not to exceed .020 inch T.I.R.

#### Mechanical

MODEL NO.	STATIC TORQUE LB. - IN.	INERTIA LB. - IN. <sup>2</sup> ARMATURE & HUB ASSEMBLY	WGT. OZ.
FSBR007	7	.0133	11
FSBR015	15	.0133	12
FSBR035	35	.084	24
FSBR050	50	.084	27
FSBR100	100	.205	56

#### Electrical

MODEL NO.	90 VDC		24 VDC		12 VDC		120 VAC	
	AMPS	OHMS	AMPS	OHMS	AMPS	OHMS	AMPS	OHMS
FSBR007	.059	1520	.247	97.3	.477	25.1	.048	N.A.
FSBR015	.098	922	.369	65.1	.719	16.7	.077	N.A.
FSBR035	.093	964	.394	61.0	.755	15.9	.073	N.A.
FSBR050	.194	465	.717	33.5	1.43	8.4	.140	N.A.
FSBR100	.180	501	.707	34	1.41	8.5	.142	N.A.

Lead wire is UL recognized style 1015, 22 gage. Insulation is .095 O.D.

#### Dimensions

MODEL NO.	HUB STYLE	A MAX.	B MAX.	C NOM.	E MAX.	F MIN.	G REF.	H MAX.	I ± .500	J NOM.	K MIN.	L NOM.	M BORES & KEYWAY		
													BORE	NOMINAL KEYWAY	
														X	Y
FSBR007	Hex Drive Only	.062	.960	.550	2.260	.605	.781	3.235	12.0	2.844	.172	5/8	1/4 5/16 3/8	.0625 - .0655 .0625 - .0655 .094 - .097	.285 - .290 .347 - .352 .417 - .427
FSBR015	Hex Drive Only	.062	1.200	.600	2.400	.605	.945	3.235	12.0	2.844	.187	5/8	5/16 3/8 1/2	.0625 - .0655 .094 - .097 .125 - .128	.347 - .352 .417 - .427 .560 - .567
FSBR035	Hex Drive Only	.094	1.905	.239	2.810	.280	.891	3.500	18.0	3.125	.200	1 1/8	3/8 1/2 5/8 3/4	.094 - .097 .125 - .128 .1885 - .1905 .1885 - .1905	.417 - .427 .560 - .567 .709 - .719 .836 - .844
FSBR050	Hex Drive Only	.094	1.905	.239	2.810	.280	.891	3.500	18.0	3.125	.200	1 1/8	3/8 1/2 5/8 3/4	.094 - .097 .125 - .128 .1885 - .1905 .1885 - .1905	.417 - .427 .560 - .567 .709 - .719 .836 - .844
FSBR100	Hex Drive Only	.140	1.870	.545	4.000	.555	1.188	5.250	18.0	4.750	.216	1 1/2	1/2 5/8 3/4	.125 - .128 .1885 - .1905 .1885 - .1905	.560 - .567 .709 - .716 .836 - .844

#### Notes:

##### Hex Drive – FSBR

- Refer to dimension "A" for the distance the hub should be installed on the shaft from the mounting surface.
- Dimension "F" is the minimum length of the hex hub.

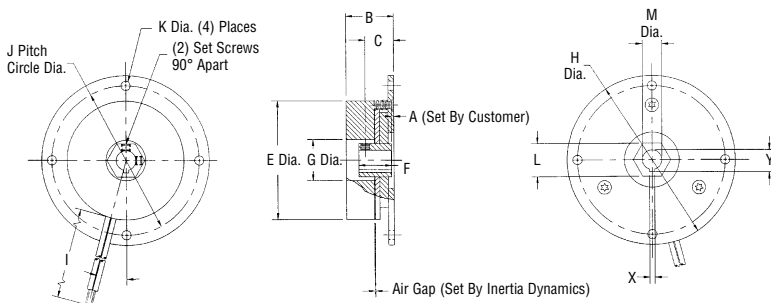

See page 29 for Ordering Information

# Spring Applied Friction Brakes

## Reverse Mounted Spring Applied Brakes – Type FSBR Metric



FSBR007 Shown

### FSBR SERIES SPRING APPLIED BRAKES

#### Reverse Mounted Spring Applied Brakes – Type FSBR

Inertia Dynamics type FSBR brakes are designed for applications requiring minimum space (short axial length) or for motors with short shaft extensions. When mounted, the hub is installed on the shaft first, then the brake is installed over the hub and attached to the motor.

#### Customer Shall Maintain:

The perpendicularity of the mounting surface with respect to the shaft not to exceed .127 mm T.I.R. at a diameter equal to the brake body outside diameter; the concentricity between the mounting holes and the shaft not to exceed .508 mm T.I.R.

#### Mechanical

MODEL NO.	STATIC TORQUE N-m	INERTIA kg-cm <sup>2</sup> ARMATURE & HUB ASSEMBLY	WGT. kg
FSBR007	.791	.039	.31
FSBR015	1.69	.039	.34
FSBR035	3.95	.246	.68
FSBR050	5.65	.246	.77
FSBR100	11.3	.600	1.58

#### Electrical

MODEL NO.	90 VDC		24 VDC		12 VDC		120 VAC	
	AMPS	OHMS	AMPS	OHMS	AMPS	OHMS	AMPS	OHMS
FSBR007	.059	1520	.247	97.3	.477	25.1	.045	N.A.
FSBR015	.098	922	.369	65.1	.719	16.7	.077	N.A.
FSBR035	.093	964	.394	61.0	.755	15.9	.073	N.A.
FSBR050	.194	465	.717	33.5	1.43	8.4	.140	N.A.
FSBR100	.180	501	.707	34	1.41	8.5	.142	N.A.

Lead wire is UL recognized style 1015, 22 gage. Insulation is 2.41 mm O.D.

#### Dimensions

MODEL NO.	HUB STYLE	A MAX.	B MAX.	C NOM.	E MAX.	F MIN.	G REF.	H MAX.	I ± 12.7	J NOM.	K MIN.	L NOM.	M BORES & KEYWAY		
													BORE	NOMINAL KEYWAY	
														X	Y
FSBR007	Hex Drive Only	1.575	24.384	2.921	57.404	15.367	19.837	82.169	304.800	72.238	4.369	15.875	6H9 8H9	1.988-2.060 1.988-2.060	7.00-7.10 9.00-9.10
FSBR015	Hex Drive Only	1.575	30.480	2.921	60.960	15.367	24.003	82.169	304.800	72.238	4.369	15.875	8H9 10H9	1.988-2.060 2.988-3.060	9.00-9.10 11.40-11.50
FSBR035	Hex Drive Only	2.388	48.387	4.572	71.374	7.112	22.631	88.900	457.200	79.375	5.080	28.575	10H9 15H9	2.988-3.060 4.985-5.078	11.40-11.50 17.30-17.40
FSBR050	Hex Drive Only	2.388	48.387	4.572	71.374	7.112	22.631	88.900	457.200	79.375	5.080	28.575	15H9 17H9	4.985-5.078 4.985-5.078	17.30-17.40 4.985-5.078
FSBR100	Hex Drive Only	3.556	47.498	4.191	101.600	14.907	30.175	133.350	457.200	120.650	5.486	38.100	15H9 17H9	4.985-5.078 4.985-5.078	17.30-17.40 4.985-5.078

#### Notes:

##### Hex Drive – FSBR

- Refer to dimension “A” for the distance the hub should be installed on the shaft from the mounting surface.
- Dimension “F” is the minimum length of the hex hub.

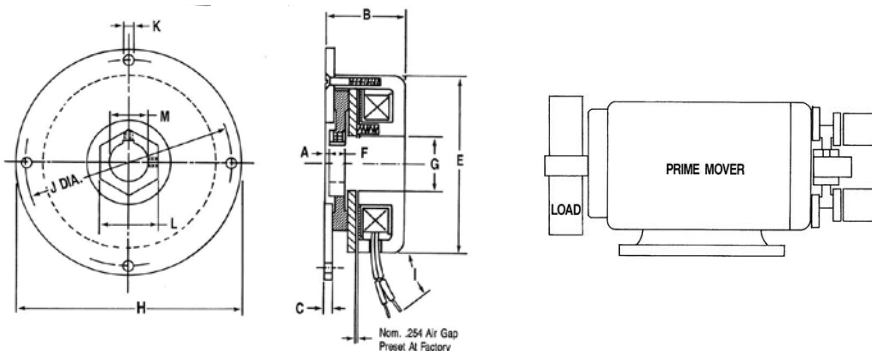

See page 29 for Ordering Information