

Spring Applied Friction Brakes

Manual Release, Spring Applied Brakes – Type FSBR

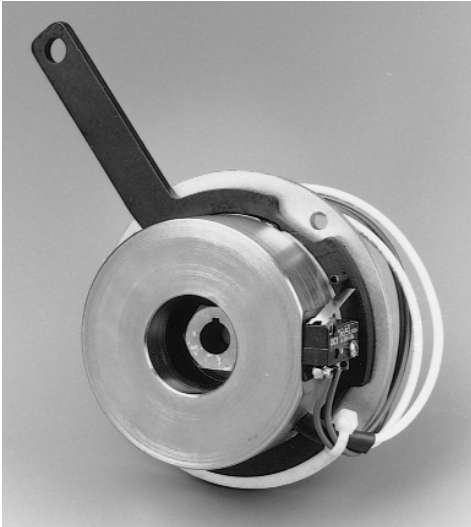

FSBR SERIES SPRING APPLIED BRAKE

Manual Release Spring Applied Brake – Type FSBR

Inertia Dynamics features a type FSBR015 spring applied brake with a manual release lever. The brake incorporates a lever which is rotated to mechanically engage the clapper plate. The armature plate acts against the compression springs and allows the friction disc to spin freely. The brake is then free of torque. An optional microswitch is activated on the field assembly to disconnect power to your system in case of an accidental start-up with the brake manually released. To return the brake to normal operation, the lever is rotated to re-engage the brake and produce torque.

Typical applications include wheelchairs, three-wheel carts/scooters, and fractional horsepower motors. The brake is available with a higher static torque rating for non-dynamic braking applications where only a statically engaged parking brake is needed.

For variations on the manual release brake configuration, in support of high volume OEM applications, consult Inertia Dynamics.

Customer Shall Maintain:

The concentricity between mounting holes and mounting shaft not to exceed .020 (.508 mm) T.I.R.; the perpendicularity of mounting face with respect to shaft not to exceed .005 (.127 mm) T.I.R.

Caution:

Inertia Dynamics recommends the use of a switch or other method to ensure this brake is not operated while it is in the manually released mode.

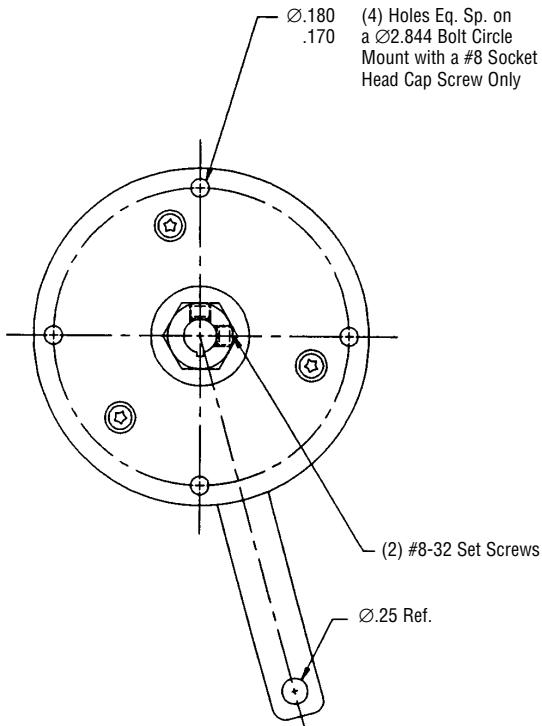

Spring Applied Friction Brakes

Manual Release, Spring Applied Brakes – Type FSBR Imperial

Bore Dimensions

HUB BORE	NOM. HEX	KEYWAY
.3130 – .3145 5/16	5/8	1/32 x 1/16
.3755 – .3770 3/8	5/8	3/64 x 3/32
.5005 – .5020 1/2	3/4	1/16 x 1/8

Electrical

VOLTS	WATTS	AMPS.	OHMS.
90 VDC	8.8	.098	922
24 VDC	8.9	.369	65.1
12 VDC	8.6	.719	16.7
120 VAC	8.7	.077	N.A.

Notes:

- Coil lead data: 22 AWG, 7/30 stranded, 105°C, 600V, UL style 1430, insulation is .064" O.D.

Mechanical

	DYNAMIC STYLE	STATIC* STYLE	INERTIA (LB. - IN. ²) ARM & HUB	WEIGHT OZ.
Static Torque (LB. - IN.)	5/8	1/32 x 1/16	1/32 x 1/16	1/32 x 1/16

- 16 lbs. pull force maximum at 3.500 length on lever arm.

* For park & hold, static braking conditions only.

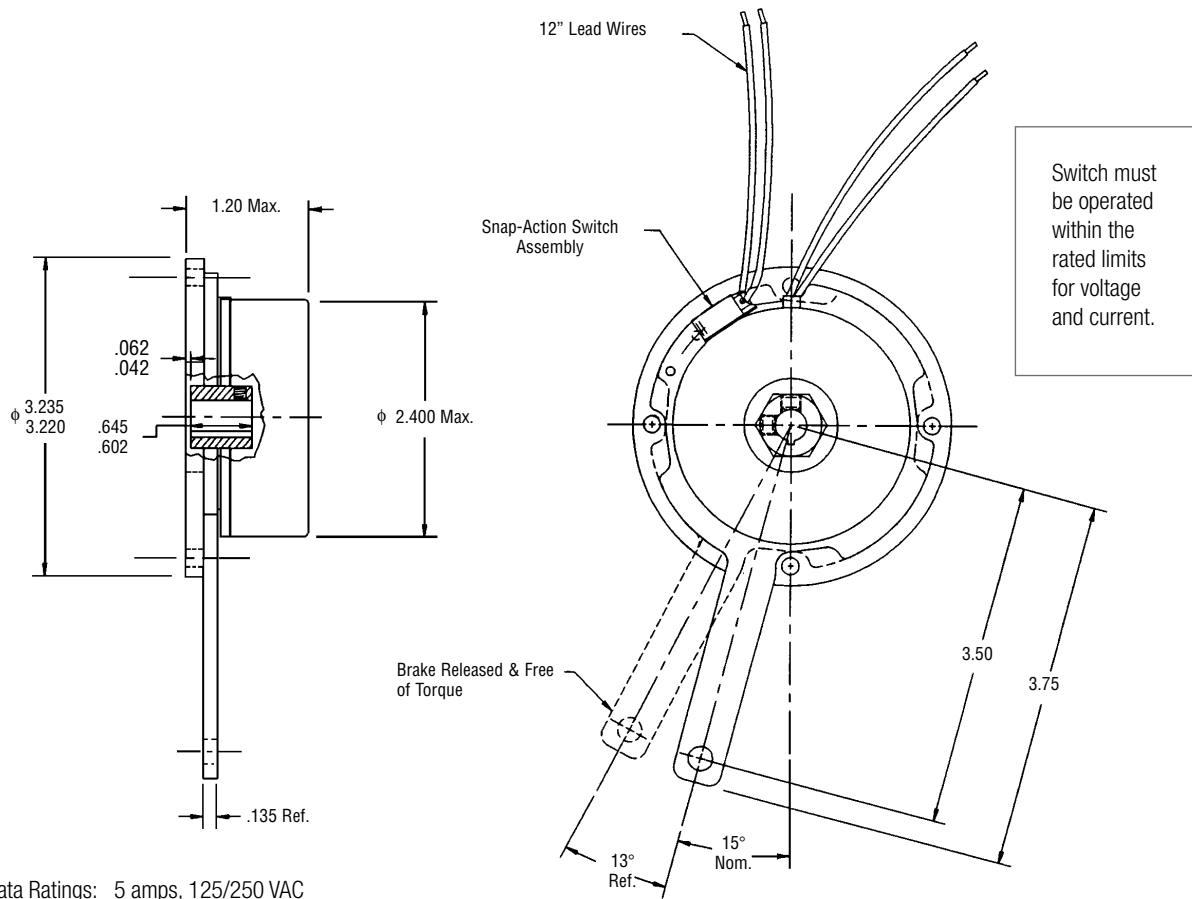

Switch must be operated within the rated limits for voltage and current.

Switch Data Ratings: 5 amps, 125/250 VAC
Double-Throw Contacts
Short Solder Terminals

Engineering may substitute a switch of equal specifications.

See page 29 for Ordering Information

Spring Applied Friction Brakes

Manual Release, Spring Applied Brakes – Type FSBR Metric

Bore Dimensions

HUB BORE	NOM. HEX	KEYWAY	
		X	Y
8H9	15.875	1.988-2.060	9.00-9.10
10H9	19.050	2.988-3.060	11.40-11.50

Electrical

VOLTS	WATTS	AMPS.	OHMS.
90 VDC	8.8	.098	922
24 VDC	8.9	.369	65.1
12 VDC	8.6	.719	16.7
120 VAC	8.7	.077	N.A.

Notes:

- Coil lead data: 22 AWG, 7/30 stranded, 105°C, 600V, UL style 1430, insulation is 1.63 mm OD .

Mechanical

	DYNAMIC STYLE	STATIC* STYLE	INERTIA (k-cm ²) ARM & HUB	WEIGHT kg
Static Torque (N-m)	1.69	3.39	0.389	.96 kg

- 67 Newtons pull force maximum at 88.900 mm length on lever arm.

* For park & hold, static braking conditions only.

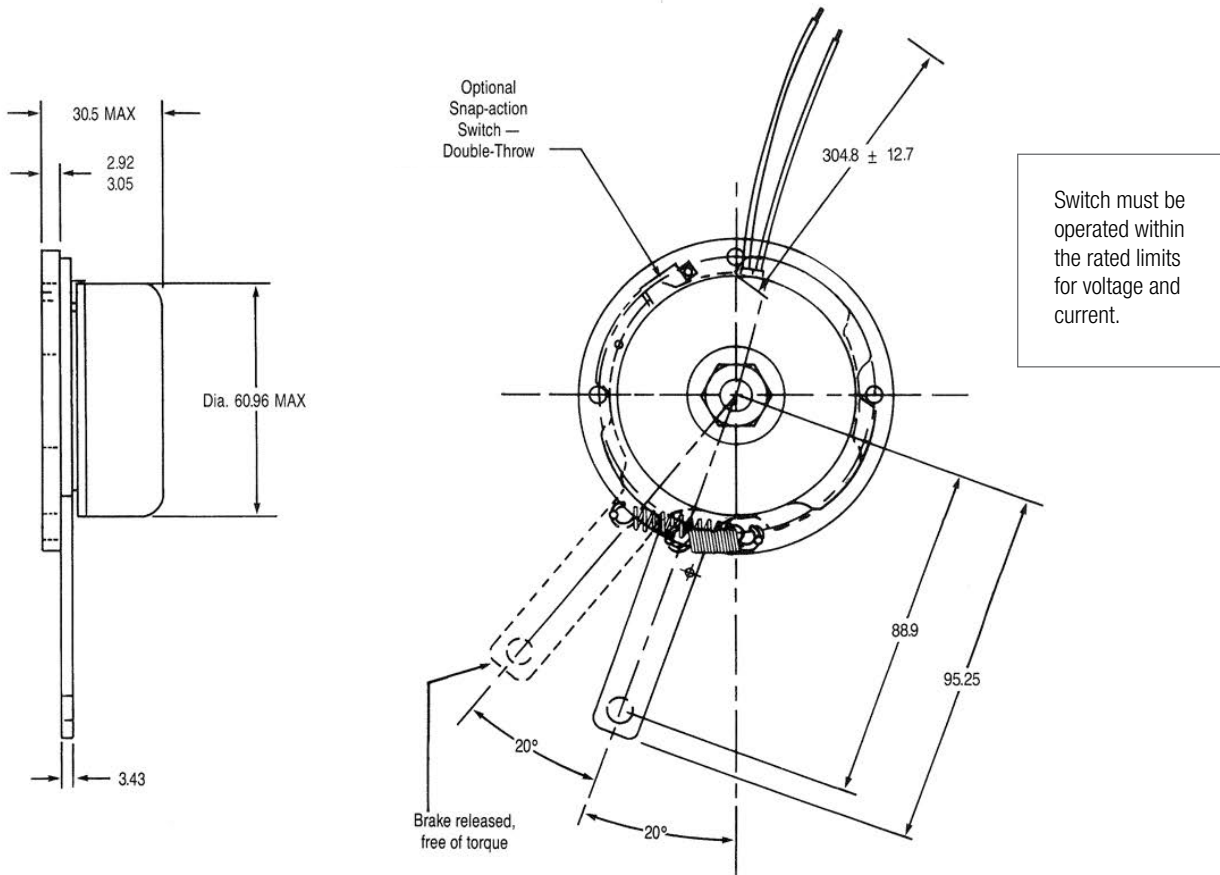

Switch Data Ratings: 5 amps, 125/250 VAC
 Double-Throw Contacts
 Short Solder Terminals

Engineering may substitute a switch of equal specifications.

See page 29 for Ordering Information