

## Models 303, 303HQ, 304, 305, 305HQ, and 308 Spring Set Brakes

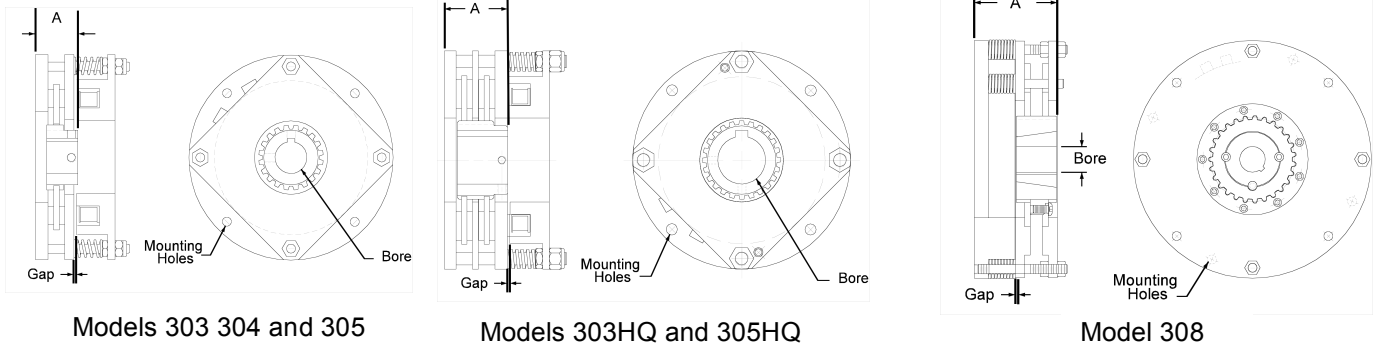

Models 303 304 and 305

Models 303HQ and 305HQ

Model 308

### Operation

Dynacorp SSB Holding brakes are spring set, electro-magnetic released, direct acting for occasional stopping and holding of a load. This brake is not designed for cyclic process stopping only holding.

With the correct DC voltage (power) is applied the brake is released and the load is free to move; when DC power is removed the springs will engage the brake. HQ models are double disc versus single disc.

**Spring set brakes (SSB) are not self adjusting and will require the gap is monitored for wear and readjustment. When the brake's friction material wears the gap will increase and the brake magnet cannot overcome the springs. If your drive system has more torque capability than the brake it will drive the load when the springs are engaged and the brake can fail due to overheating and will not be capable of holding your load in position. Monitor the Gap for wear.**

### Installation:

SSB Holding Brakes are burnished at the factory to give full holding torque "Out of the Box" and do not require adjustments at installation. Brake assembly consists of two items: Brake body and splined hub. Mount splined hub on shaft to dimension "A" from the brakes mounting surface. Slide the brake over the hub and bolt to your mounting surface. See data for alignment of this brake to the mounting surface.

Hub position and alignment of Brake mounting surface to shaft.

Model	Holding Torque	Dimension "A"	Concentricity	Perpendicularity
303	35 In-Lbs	.062	.015	.006
303HQ	60 In-Lbs	1.44	.015	.006
304	225 In-Lbs	1.23	.015	.006
305	425 In-Lbs	1.35	.020	.006
305HQ	800 In-Lbs	1.88	.020	.006
308	1200 In-Lbs	3.25	.030	.010

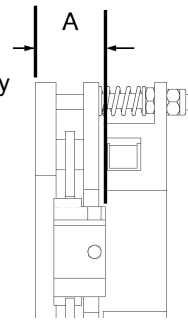

### Adjustments:

Adjust the gap when brake wears to re-adjust dimension to initial gap dimension. Adjust by turning the two sets of nuts on each stud. It is important the gap be uniform and measured at mid points between the springs. Measure gap after tightening nuts and readjust as required. If friction material is less than minimum thickness and or out of parallel more than .004 to plate replace the friction plates or brake.

Model	Initial Gap	Re-adjust Gap	Min Friction Material
303	.004/.006	.015	.050
303HQ	.004/.006	.015	.050
304	.006/.008	.020	.075
305	.006/.008	.020	.075
305HQ	.008/.010	.020	.075
308	.014/.017	.035	.125

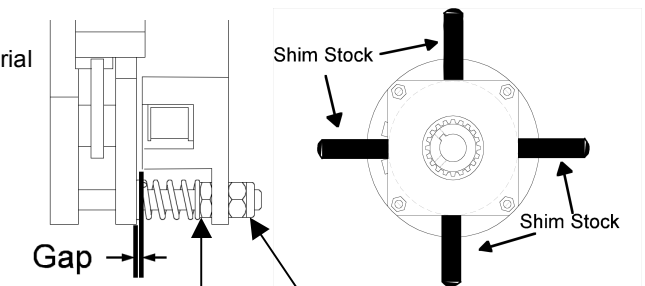

**Adjusting Nuts**