

Wrap Spring Clutch-Brakes

DCB-10 & DCB-10 SUPER Dimensions

Product Function: Start-Stop 

Specifications

Maximum Speed:	200 RPM	Max. Anti-overrun Torque:	1200 in.-lb.	Positioning Accuracy:	$\pm 1/2^\circ$
Static Torque:	5000 in.-lb	Max. Anti-back Torque:	1200 in.-lb.	Weight:	28 lbs.

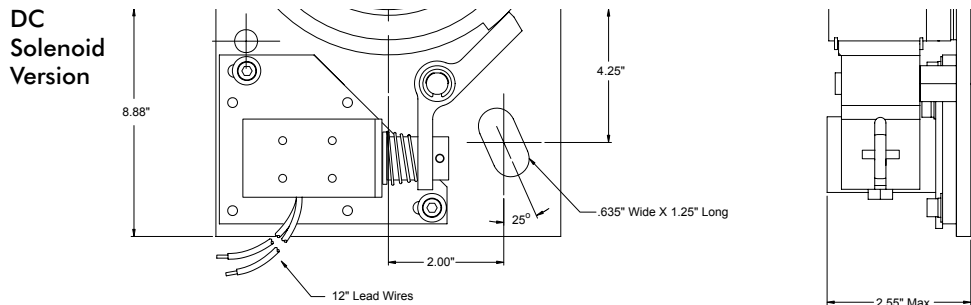
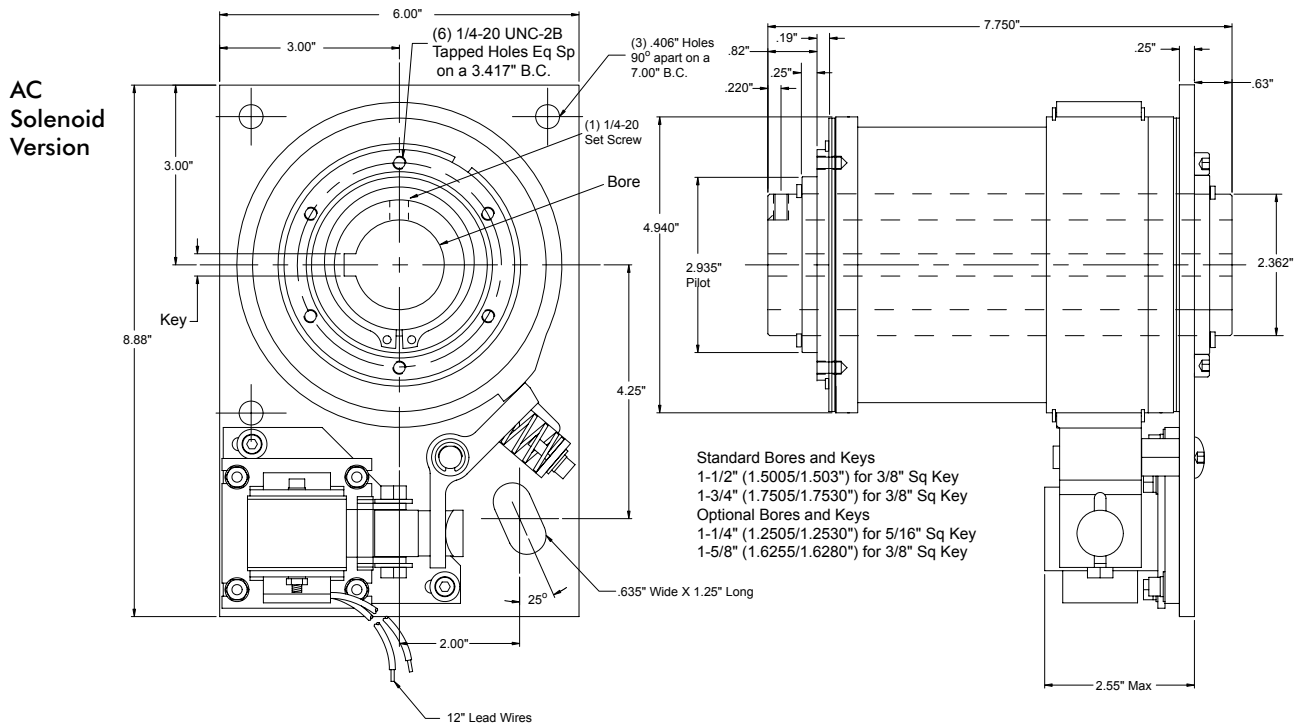

DCB-10 Part Numbers

 CLOCKWISE ROTATION SHOWN

Part Number		Description			
CW Rotation	CCW Rotation	Model	Bore	Voltage	Stops
D300-12-033	D300-22-033	DCB10	1-1/2"	115VAC	1
D300-12-051	D300-22-047	DCB10	1-1/2"	115VAC	2
D300-12-044	D300-22-041	DCB10	1-1/2"	115VAC	4
D300-17-051	D300-27-030	DCB10	1-1/2"	24VDC	1
D300-17-052	D300-27-051	DCB10	1-1/2"	24VDC	2
D300-17-053	D300-27-052	DCB10	1-1/2"	24VDC	4

DCB-10 SUPER Part Numbers

Part Number		Description			
CW Rotation	CCW Rotation	Model	Bore	Voltage	Stops
D320-12-001	D320-22-001	DCB10 SUPER	1-1/2"	115VAC	1
D320-12-002	D320-22-002	DCB10 SUPER	1-1/2"	115VAC	2
D320-12-003	D320-22-003	DCB10 SUPER	1-1/2"	115VAC	4
D320-17-010	D320-27-010	DCB10 SUPER	1-1/2"	24VDC	1
D320-17-011	D320-27-011	DCB10 SUPER	1-1/2"	24VDC	2
D320-17-012	D320-27-012	DCB10 SUPER	1-1/2"	24VDC	4

Wrap Spring Clutch-Brakes – Replacement Parts

DCB-10 & DCB-10 SUPER Replacement Parts

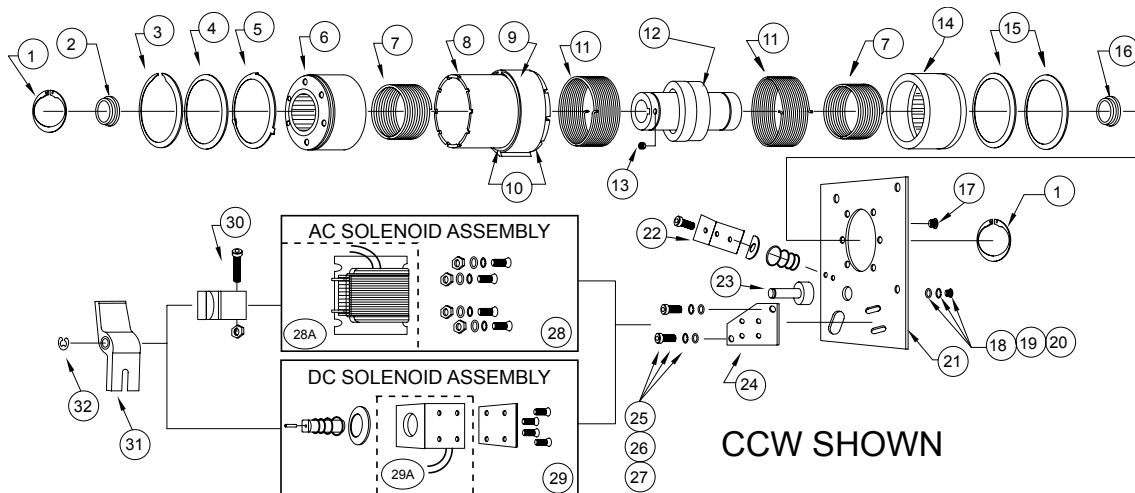

Item	Part No.	Rotation - Bore or Voltage	Description
1	040-03123		(2) Retaining Ring (5100-237)
2	D950-10-0002		Input Thrust Washer
3	040-03126		Retaining Ring (US-381)
4	D807-10-0001		Collar Spacer
5	D807-10-0002		Tabbed Input Collar Spacer
6	D541-10-0003		Input Hub
	D541-10-0001		Super - Input Hub with Wear Ring
7	D808-0-0001	CW	(2) Anti-Overrun / Anti-Back Spring
	D808-0-0002	CCW	
8	D803-10-0001	CW or CCW	Collar Sleeve
9	D245-0-0101	CW or CCW	1 Stop Cam
	D245-0-0102	CW or CCW	2 Stop Cam
	D245-0-0104	CW or CCW	4 Stop Cam
10	040-03121		(2) Retaining Ring (US-500)
11	D808-0-0009	CW	(2) Clutch / Brake Spring
	D808-0-0010	CCW	
12	D824-10-0009	1-1/2"	Output Shaft
	D824-10-0011	1-3/4"	
	D824-10-0002	1-1/2"	Super - Output Shaft with Wear Rings
	D824-10-0004	1-3/4"	
13	040-04492		Set Screw Cup Point (1/4-20 x 3/8 Long)
14	D541-10-0006		Brake Hub
	D541-10-0005		Super - Brake Hub with Wear Ring
15	D807-10-0003		(A/R) Brake Collar Spacer
16	D950-10-0001		Brake Thrust Washer
17	040-04227		(6) Cap Screws (1/4-20 x 5/8 Long)
18	040-06118		Flat Washer (3/8)
19	040-0694		Lock Washer (3/8)
20	040-04493		Button Head Cap Screw (3/8-24 x 3/4 Long)
21	D686-10-0001	CW or CCW	Plate
22	D102-10-0003	AC Only	Actuator Return Spring Assembly
23	D679-10-0001		Actuator Post
24	D686-10-0002		Solenoid Plate
25	040-04487		(2) Cap Screws (10-32 x 5/8 Long)
26	040-0688		(2) Lock Washer (#10)
27	040-06159		(2) Flat Washer (#10)
28	D101-10-0001	CW - 115VAC	AC Coil Assembly - Incl. Coil & Hardware
	D101-10-0002	CCW - 115VAC	
28A	D275-1-0579	CW - 115VAC	AC Coil Only
	D275-1-0580	CCW - 115VAC	
29	D101-10-0005	CW or CCW - 24VDC	DC Coil Assembly - Incl. Coil & Hardware
29A	D275-1-0073	24VDC	DC Coil Only
30	D102-10-0002	AC Only	Actuator Link Assembly
31	D102-10-0001		Actuator
32	040-03125		Retaining Ring (5133-37)