

Wrap Spring Clutches

DCB Performance Features

Single Position Output Made Easy With DCB Series Wrap Spring Clutch-Brakes

- **Stop Position Accuracy $\pm 1/2^\circ$**
- **Adjustable Output Stop Positions**
- **Standard Features**
 - CW or CCW Rotation
 - Hub Input - Shaft Output
 - Anti-Overrun
 - Output Does Not Overrun Input
 - Anti-Back
 - Output Does Not Backup
- **Stocked with Single Stop 115VAC Solenoid**
 - 2 and 4 Stop Available for 180° and 90° Output Increments
- **115VAC and 24VDC Solenoids Standard**
 - Other Voltages Available
- **Dimensionally Interchangeable With Competitive Units**
- **8 Standard Models**
 - DCB-2 – DCB-4
 - DCB-5 – DCB-5 SUPER
 - DCB-6 – DCB-6 SUPER
 - DCB-8 – DCB-8 SUPER

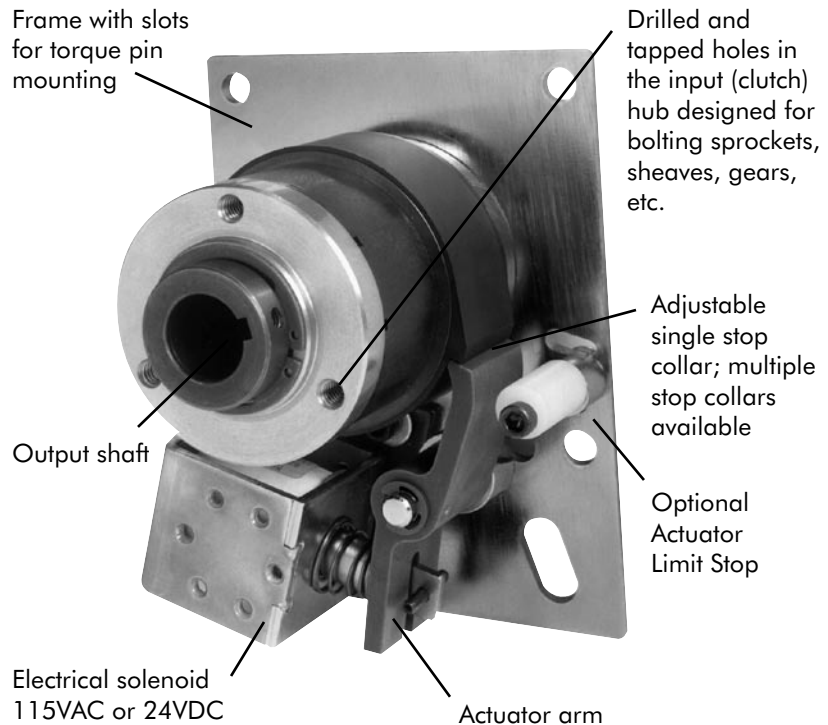

Unit Shown is CW Rotation, CCW is Available

Operation

To start motion, the solenoid is pulsed, moving an actuator arm away from a control collar. This allows the clutch spring to wrap (wind) down onto the output assembly while the brake spring is unwinding, allowing the output to drive. Motion is stopped when the actuator returns to its rest position and the control collar rotates into it. This forces the clutch spring to unwind, releasing the input from the output and wraps the brake spring down, stopping the output. The anti-back and anti-overrun springs are key items in maintaining position accuracy during operation. Anti-back will not allow the output to rotate backwards at any time; this eliminates bounce back when stopped. The anti-overrun allows rotation of the input in one direction only and also keeps the output from rotating faster than the input. The actual stopping position can be adjusted after installation by moving the splined cam of the control collar assembly.

The input is a hub with drilled and tapped holes to allow mounting of sprockets, gears, sheaves, etc. The output is a hollow quill that mounts onto the customer's driven shaft. The plate must be held in place by a loose-fit pin that does not allow any side or radial loads that can preload the unit's bearings.

Supers vs. Standard

All units have three primary sintered iron hubs that are oil impregnated; input, brake and an internal hub pinned to the output shaft. On standard units the oil lubricates the bearing surfaces of the input and brake hubs which ride on the output shaft, whereas the Supers use needle bearings in the input and brake hubs to increase the radial bearing load capability. All types require the oil in the hubs to lubricate the springs. The Supers feature hardened steel wear rings on the primary hubs at the spring crossover point of the clutch, brake and shaft hubs to increase life. The control collar assemblies are glass-reinforced nylon strengthened by steel or aluminum inserts. The actuators are Delrin® AF on all models.

DCB Product Selection

Basic Selection

Step 1:

To select the correct DCB Series wrap spring, determine the maximum speed (RPM) at which the unit will operate. Next, determine the load that the output will need to drive and the system inertia. See Page J-29 for inertia calculations.

Step 2:

Determine the shaft size on which the wrap spring will be mounted. Once this is determined, the appropriate size DCB can be determined.

Step 3:

Determine clockwise (CW) or counter-clockwise (CCW) rotation, AC or DC solenoid, number of stops required.

DCB Specifications

Model	Static Torque In.-Lbs.	Maximum Input Speed	Minimum* Input Speed	Anti-Back Torque In.-Lbs.	Anti-Overrun Torque In.-Lbs.	Input Hub Maximum Bearing Load Lbs.
DCB-2	25	1800	300	10	10	7.5
DCB-4	125	1200	200	80	25	14
DCB-5	250	750	150	160	45	32
DCB-5 SUPER	250	750	150	125	125	40
DCB-6	500	500	100	300	300	63
DCB-6 SUPER	500	500	100	300	300	65
DCB-8	2500	300	50	600	600	300
DCB-8 SUPER	2500	300	50	600	600	300

* When operating below minimum speeds, system inertias may have to be increased for proper product performance. Consult factory for application assistance.

Model	115VAC Solenoids			24VDC Solenoids	
	Resistance Ohms $\pm 10\%$	Current Amps In-Rush Holding		Resistance Ohms $\pm 10\%$	Current Amps
DCB-2	825	.10	.05	104	.23
DCB-4	280	.22	.10	74.0	.32
DCB-5	280	.22	.10	74.0	.32
DCB-5 SUPER	280	.22	.10	74.0	.32
DCB-6	53	.62	.31	40.0	.60
DCB-6 SUPER	53	.62	.31	40.0	.60
DCB-8	53	.62	.31	40.0	.60
DCB-8 SUPER	53	.62	.31	25.4	.94