

Spring Set Holding Brake

Model

● 305HQ

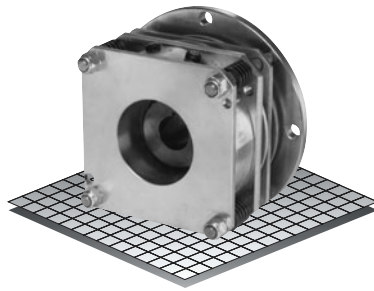

- ▶ Factory Assembled and Tested
- ▶ Spline Drive
- ▶ Double Disc

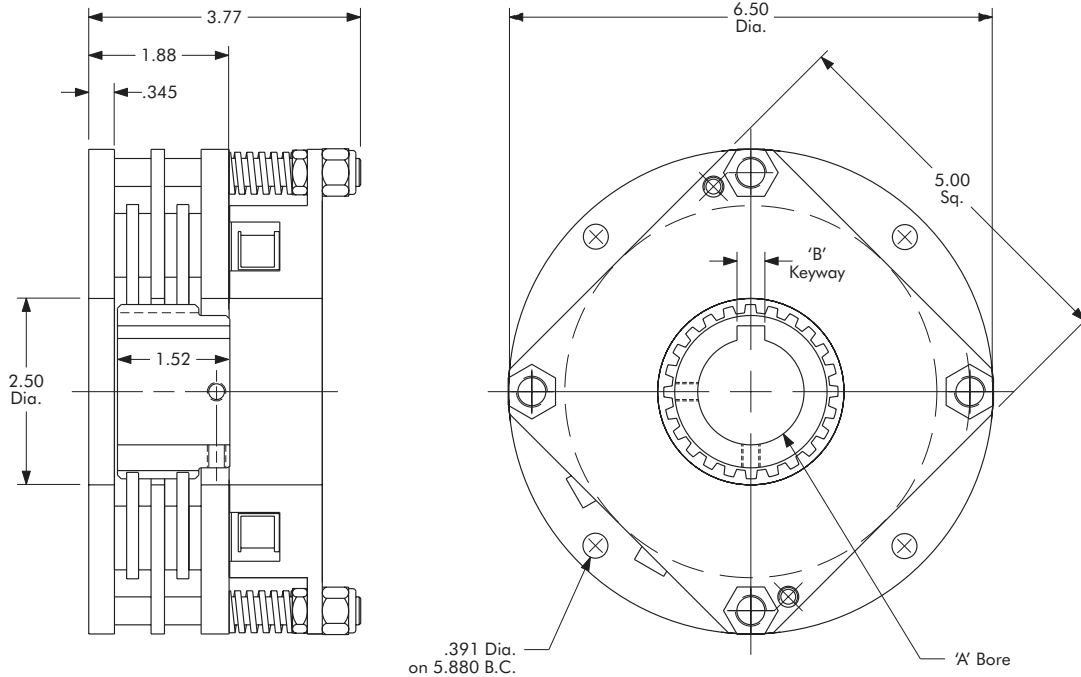

Bore "A"	"B" Keyway
3/4"	None
1"	.250 x .125
1-1/4"	.250 x .125
1-1/2"	.375 x .187

Technical Data

Model No.	Wt. Lbs.	Static Torque in. lb.	Coil Voltage vdc	* Rated Current amps
305HQ	11.5	800	90	.427

* Rated Current for 90v.

Customer must maintain:

1. Concentricity between mounting flange and shaft within .006.
2. Perpendicularity between mounting surface and shaft within .006.

Order Parts for Assembly No. FC305071

Item	Qty.	Description	Model No. 305HQ
A	1	Rotor Hub Assembly 3/4" Plain Bore 1" Bore 1-1/4" Bore 1-1/2" Bore	305466-DPB 305453-20 305453-22 305453-17
M	1	Spring Set Holding Brake Double Disc 24 Volts 90 Volts	305072-3 305072-4

To order, specify: 1, Spring Set Holding Brake of required voltage
1, Rotor Hub Assembly of required bore size.

For recommended 90V control (D2400) see Section K.

Spring Set Holding Brake – Replacement Parts

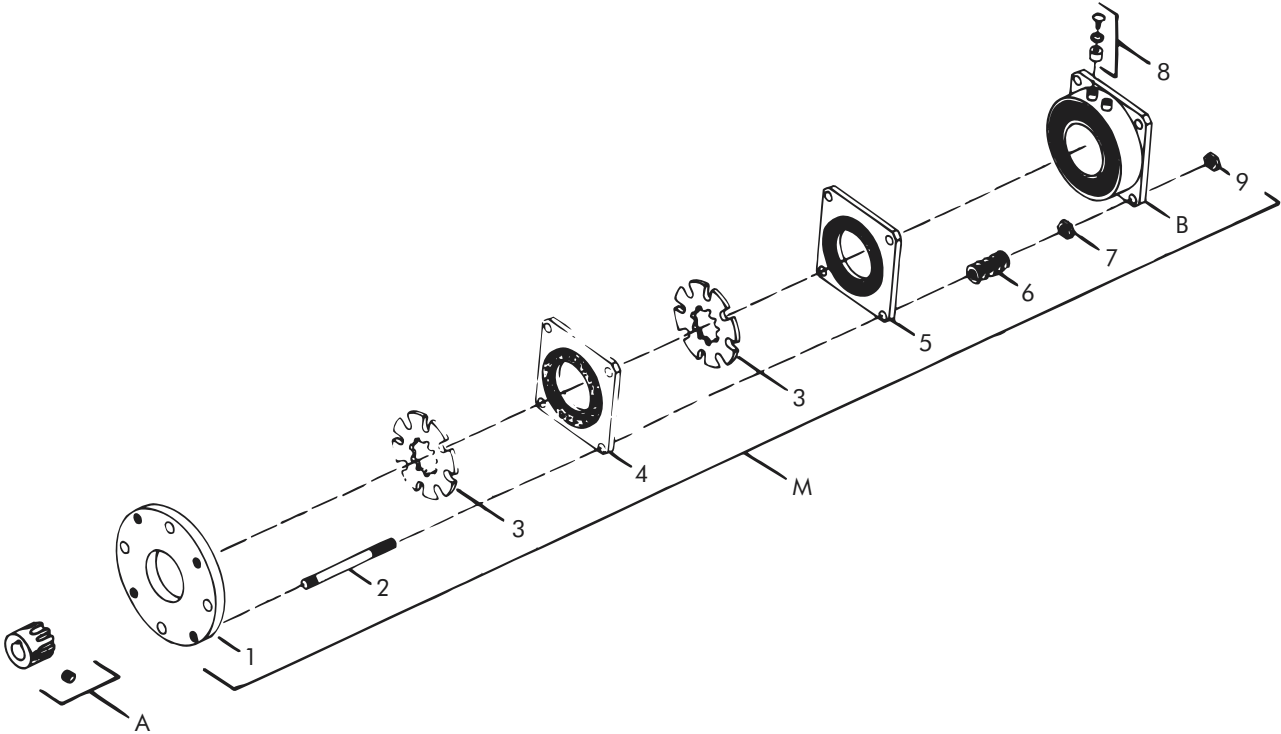

Replacement Parts

Item	Qty.	Description	Model No. 305HQ
B	1	Coil Assembly 24 Volts 90 Volts	305333-2 305334-2
1	1	Back Plate	305810
2	4	Studs	326631
3	2	Rotor (24 Teeth)	305811
4	1	Float Plate	305812-2
5	1	Flapper	305812
6	4	Springs	326795
7	4	Nuts	DY-358
8	1	Accessory Kit	326146-1
9	4	Nuts	RY-20135