

Sheave Clutch

Models

● 307

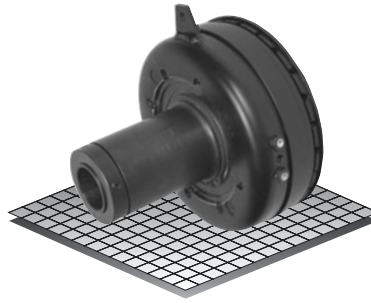

- ▶ Factory Assembled and Tested
- ▶ Bearing Mounted
- ▶ Spline Drive

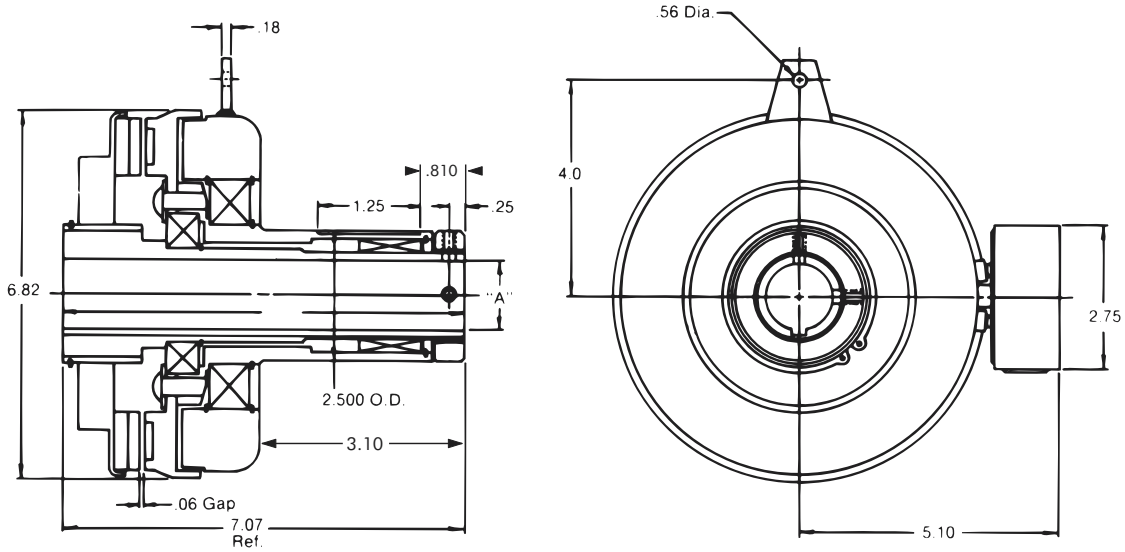

Bore "A"	Keyway
1"	.250 / .251
1-1/8"	.250 / .251
1-1/4"	.250 / .251
*1-3/8"	.312 / .313

*Special Key Furnished

Technical Data and Torque (In. Lb.)

Model No.	Wt. Lbs.	Static Torque in. lb.	Max. Speed RPM	Coil Voltage vdc	* Rated Current amps	RPM									
						0	300	600	900	1200	1500	1800	2400	3000	3600
307	15.4	1500	3600	90	.48	1500	1320	1140	1020	960	900	804	636	516	420

Refer to Section M for torque and heat dissipation curves.

* Rated Current for 90v.

	Model No. 307
24 Volts, 1" Bore	307141-19
24 Volts, 1-1/8" Bore	307141-23
24 Volts, 1-1/4" Bore	307141-27
24 Volts, 1-3/8" Bore	307141-31
90 Volts, 1" Bore	307141-20
90 Volts, 1-1/8" Bore	307141-24
90 Volts, 1-1/4" Bore	307141-28
90 Volts, 1-3/8" Bore	307141-32

To order, use number shown in Table above.
For controls, see Section K.

Sheave Clutch – Replacement Parts

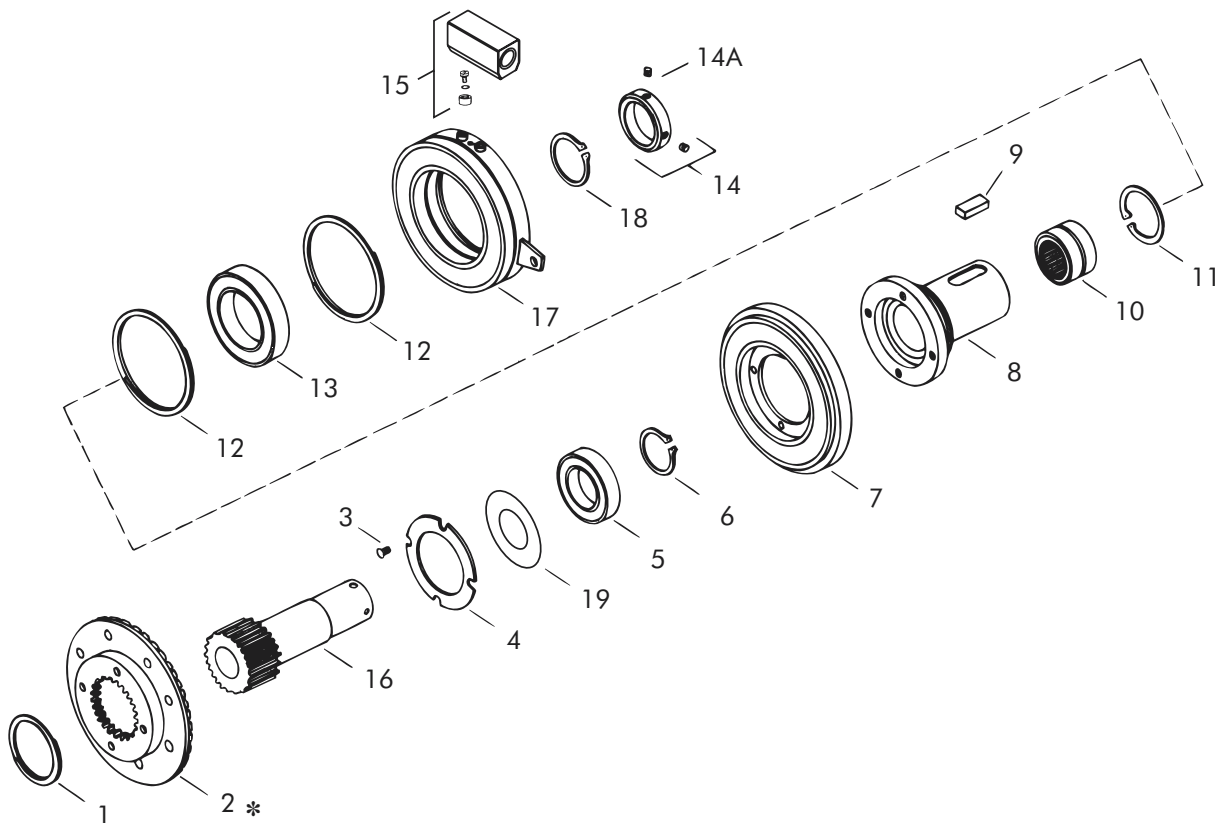

Replacement Parts

Item	Qty.	Description	Part No.	Item	Qty.	Description	Part No.
1	1	Retaining Ring (External)	RY-20207	14-A	2	Set Screw	DY-12665
2	1	Armature Assembly	307382-1	15	1	Clutch Accessory	326690
3	4	Screw	RY-20110	16	1	Drive Sleeve	
4	1	Bearing Retainer	326686			1" Bore	307821-9
5	1	Bearing	DY-6953			1-1/8" Bore	307821-10
6	1	Retaining Ring (External)	RY-20109			1-1/4" Bore	307821-11
7	1	Rotor Assembly	307820-11			1-3/8" Bore	307821-12
8	1	Bearing Hub	307752	17	1	Field	
9	1	Key	326688			24 Volts	307733-1
10	1	Needle Bearing	RY-20107			90 Volts	307734-1
11	1	Retaining Ring (Internal)	RY-20108	18	1	Retaining Ring (External)	RY-20037
12	2	Retaining Ring (Internal)	RY-20042	19	1	Felt Washer	326769-2
13	1	Bearing	RY-20047				
14	1	Lock Collar	326685				

* Current design armatures are solid.