

Shaft Mounted Brake

Model

● 310

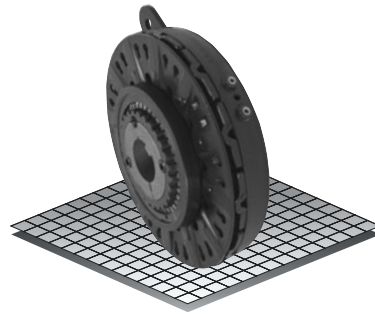

- ▶ Factory Assembled and Tested
- ▶ Bearing Mounted
- ▶ Spline Drive

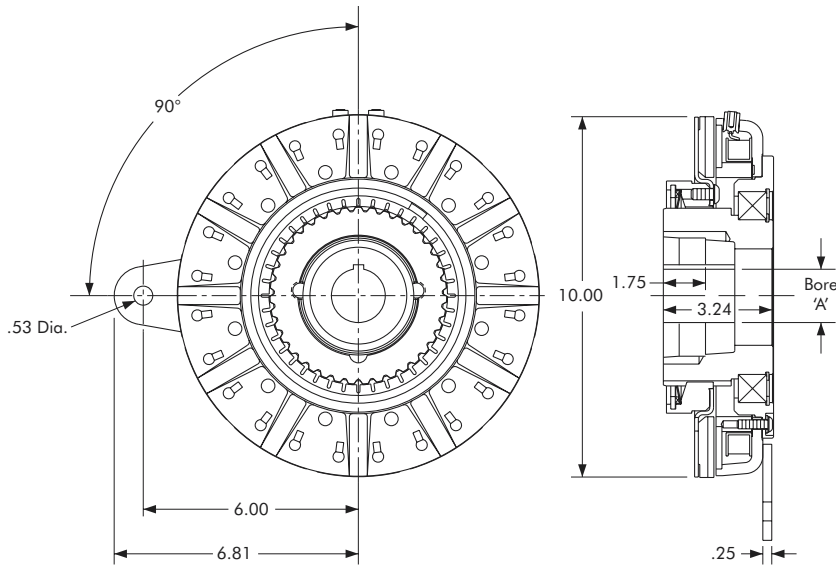

Bushing 2517

Bore 'A'		Keyway	Part No.
1/2"	.500	.125 x .062	326039 - 1
9/16"	.562	.125 x .062	326039 - 2
5/8"	.625	.187 x .093	326039 - 3
11/16"	.687	.187 x .093	326039 - 4
3/4"	.750	.187 x .093	326039 - 5
13/16"	.812	.187 x .093	326039 - 6
7/8"	.875	.187 x .093	326039 - 7
15/16"	.937	.250 x .125	326039 - 8
1"	1.000	.250 x .125	326039 - 9
1-1/16"	1.062	.250 x .125	326039 - 10
1-1/8"	1.125	.250 x .125	326039 - 11
1-3/16"	1.187	.250 x .125	326039 - 12
1-1/4"	1.250	.250 x .125	326039 - 13
1-5/16"	1.312	.312 x .156	326039 - 14
1-3/8"	1.375	.312 x .156	326039 - 15
1-7/16"	1.437	.375 x .187	326039 - 16
1-1/2"	1.500	.375 x .187	326039 - 17
1-9/16"	1.562	.375 x .187	326039 - 18
1-5/8"	1.625	.375 x .187	326039 - 19
1-11/16"	1.687	.375 x .187	326039 - 20
1-3/4"	1.750	.375 x .187	326039 - 21
1-13/16"	1.812	.500 x .250	326039 - 22
1-7/8"	1.875	.500 x .250	326039 - 23
1-15/16"	1.937	.500 x .250	326039 - 24
2"	2.000	.500 x .250	326039 - 25
2-1/16"	2.062	.500 x .250	326039 - 26
2-1/8"	2.125	.500 x .250	326039 - 27
2-3/16"	2.187	.500 x .250	326039 - 28
2-1/4"	2.250	.500 x .250	326039 - 29
2-5/16"	2.312	.625 x .187	326039 - 30
2-3/8"	2.375	.625 x .187	326039 - 31
2-7/16"	2.437	.625 x .187	326039 - 32
2-1/2"	2.500	.625 x .187	326039 - 33

Technical Data and Torque (In. Lb.)

Model No.	Wt. Lbs.	Static Torque in. lb.	Max. Speed RPM	Coil Voltage vdc	* Rated Current amps	RPM							
						0	300	600	900	1200	1500	1800	2400
310	25.1	3600	2400	90	.60	3600	3144	2616	2088	1788	1596	1416	1044

* Rated Current for 90v.

Refer to Section M for torque and heat dissipation curves.

Order Parts for Assembly No. FC310090

	Shaft Mounted Brake	Tapered Bushing (2517)
24 Volts	310090-3	326039-XX
90 Volts	310090-4	326039-XX

To order, specify: 1, shaft mounted brake of required voltage
1, bushing plus bore size.

For controls, see Section K.

Shaft Mounted Brake – Replacement Parts

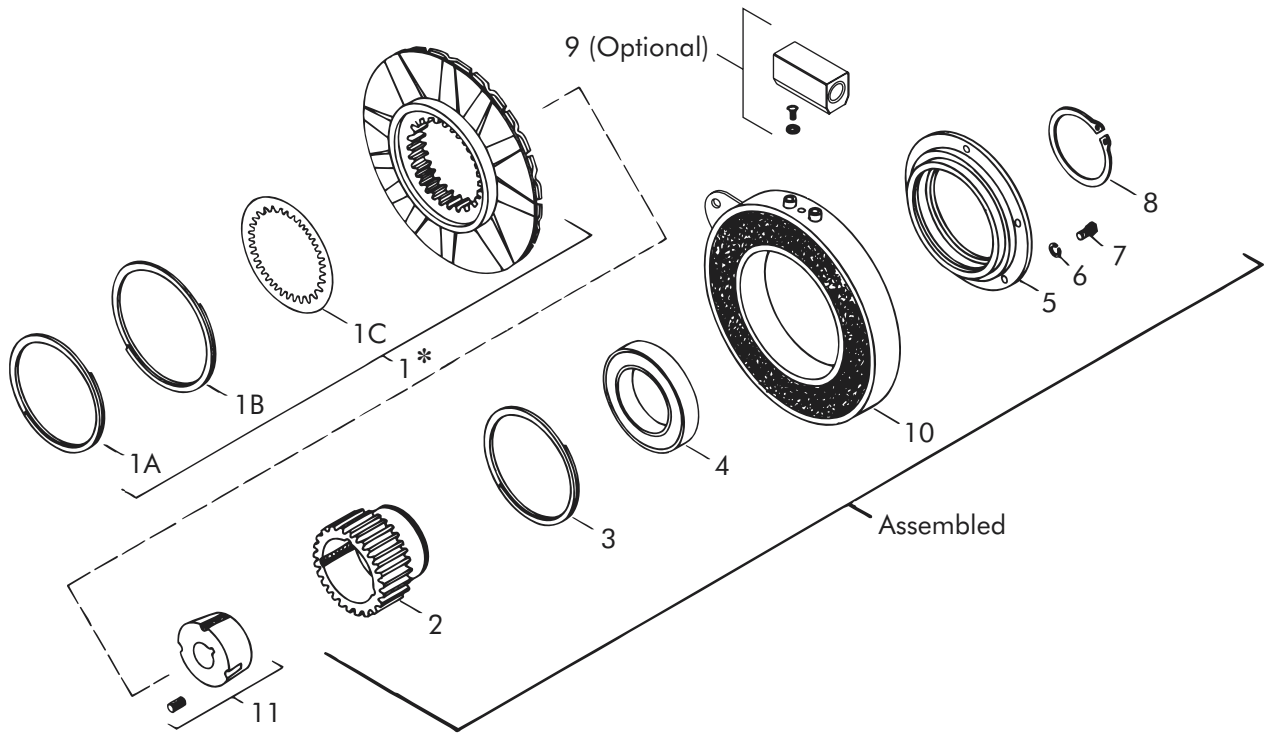

Replacement Parts

Item	Qty.	Description	Part No.	Item	Qty.	Description	Part No.
1	1	Armature Assembly	310383-13	8	1	Retaining Ring (External)	RY-20295
1-A	1	Snap Ring	RY-20317	9	1	Conduit Box (Optional)	326078
1-B	1	Adjustable Gap Spring	326970	B	1	Magnet	
1-C	1	Drag Spring	326277			24 Volts	310373-16
2	1	Splined Hub	310680-5			90 Volts	310374-16
3	1	Retaining Ring (Internal)	RY-20294	10	1	Torque Arm Kit (Opt.) (not shown)	327144
4	1	Bearing	RY-20102	11	1	Taper Bushing	326039-XX
5	1	Bearing Flange	310752-2				
6	6	Lock Washer	DY-4366				
7	6	Button Head Screw	327139				

See Page E-12 for information on Torque Arm Kit.

* Current design armatures are solid.