

Shaft Mounted Brake

Model

● 308

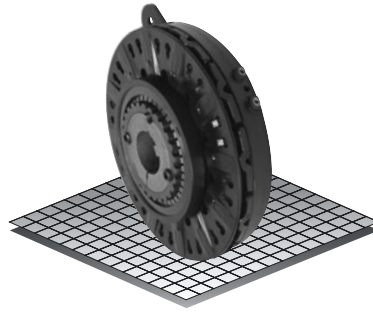

- ▶ Factory Assembled and Tested
- ▶ Bearing Mounted
- ▶ Spline Drive

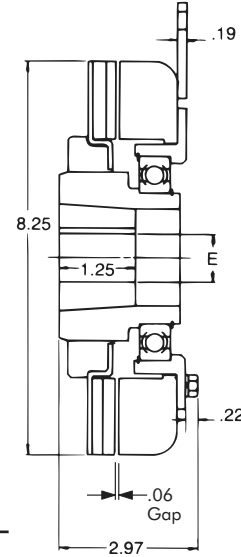
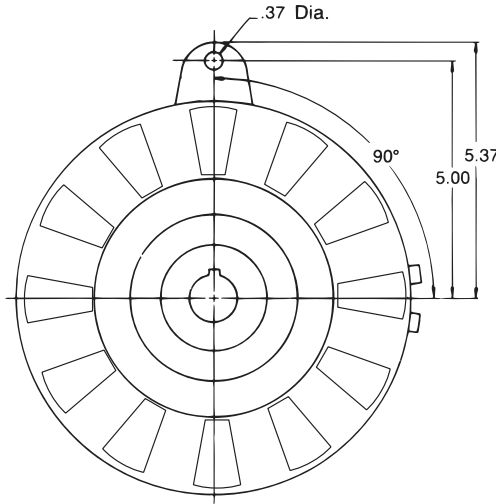

Bushing 2012

Bore 'E'		Keyway	Part No.
1/2"	.500	.125 x .062	326167 - 8
9/16"	.562	.125 x .062	326167 - 9
5/8"	.625	.187 x .093	326167 - 10
11/16"	.687	.187 x .093	326167 - 11
3/4"	.750	.187 x .093	326167 - 12
13/16"	.812	.187 x .093	326167 - 13
7/8"	.875	.187 x .093	326167 - 14
15/16"	.937	.250 x .125	326167 - 15
1"	1.000	.250 x .125	326167 - 16
1-1/16"	1.062	.250 x .125	326167 - 17
1-1/8"	1.125	.250 x .125	326167 - 18
1-3/16"	1.187	.250 x .125	326167 - 19
1-1/4"	1.250	.250 x .125	326167 - 7
1-5/16"	1.312	.312 x .156	326167 - 20
1-3/8"	1.375	.312 x .156	326167 - 6
1-7/16"	1.437	.375 x .187	326167 - 21
1-1/2"	1.500	.375 x .187	326167 - 1
1-9/16"	1.562	.375 x .187	326167 - 22
1-5/8"	1.625	.375 x .187	326167 - 2
1-11/16"	1.687	.375 x .187	326167 - 23
1-3/4"	1.750	.375 x .187	326167 - 3
1-13/16"	1.812	.500 x .250	326167 - 24
1-7/8"	1.875	.500 x .250	326167 - 4
1-15/16"	1.937	.500 x .187	326167 - 25
2"	2.000	.500 x .187	326167 - 5

Technical Data and Torque (In. Lb.)

Model No.	Wt. Lbs.	Static Torque in. lb.	Max. Speed RPM	Coil Voltage vdc	* Rated Current amps	RPM									
						0	300	600	900	1200	1500	1800	2400	3000	3600
308	16.5	2100	3600	90	.57	2100	1848	1596	1428	1344	1260	1128	888	720	588

* Rated Current for 90v.

Refer to Section M for torque and heat dissipation curves.

Order Parts for Assembly No. FC308090

	Shaft Mounted Brake	Tapered Bushing (2012)
24 Volts	308090-3	326167-XX
90 Volts	308090-4	326167-XX

To order, specify: 1, shaft mounted brake of required voltage
1, bushing plus bore size.

For controls, see Section K.

Shaft Mounted Brake – Replacement Parts

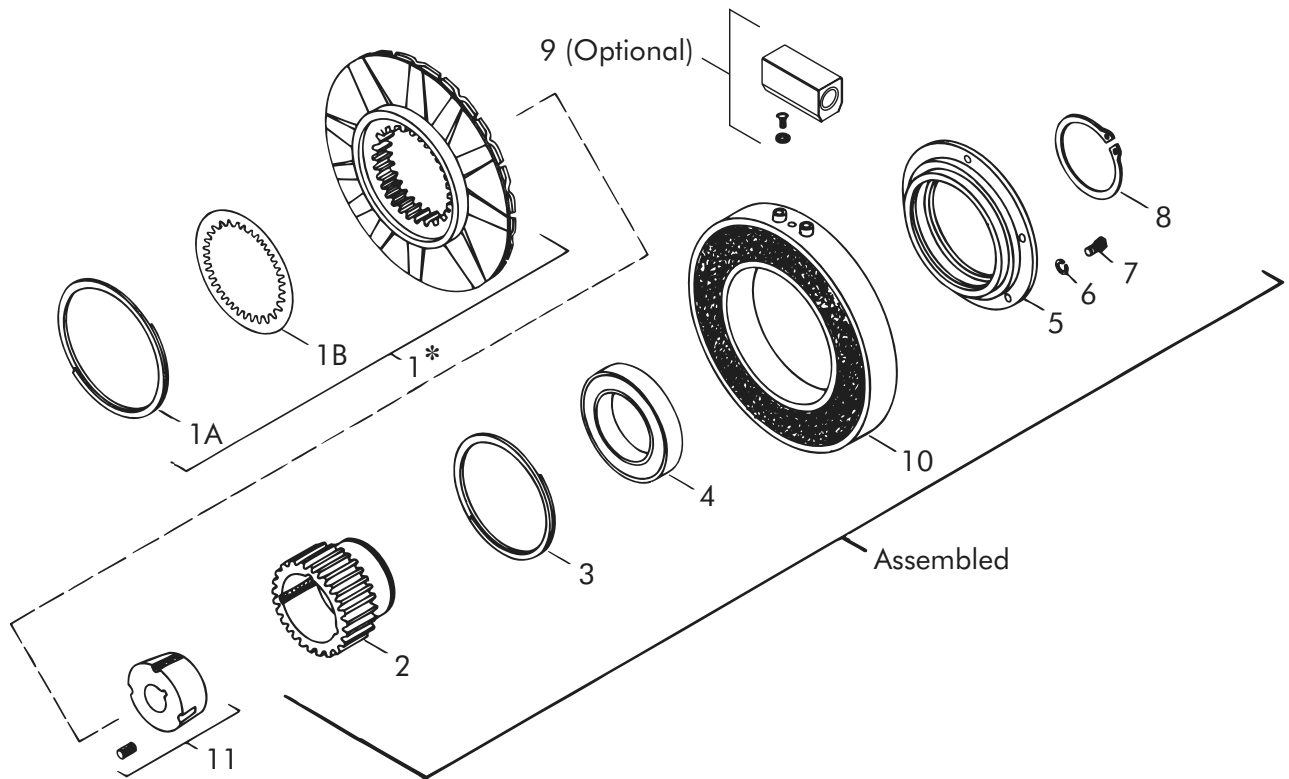

Replacement Parts

Item	Qty.	Description	Part No.	Item	Qty.	Description	Part No.
1	1	Armature Plate Assembly	308382-4	9	1	Conduit Box (Optional)	326078
1-A	1	Adjustable Gap Spring	326273	10	1	Magnet	
1-B	1	Drag Spring	326276			24 Volts	308373-27
2	1	Splined Hub	308680-3			90 Volts	308374-27
3	1	Retaining Ring (Internal)	RY-20042	11	1	Taper Bushing (2012)	326167-XX
4	1	Bearing	RY-20047	12	1	Torque Arm Kit (Opt.) (not shown)	327047
5	1	Bearing Flange	308752				
6	6	Lock Washer	DY-4366				
7	6	Hex Head Bolt	DY-14764				
8	1	Retaining Ring (External)	RY-20037				

See Page E-12 for information on Torque Arm Kit.

* Current design armatures are solid.