

Shaft Mounted Brake

Model

● 305

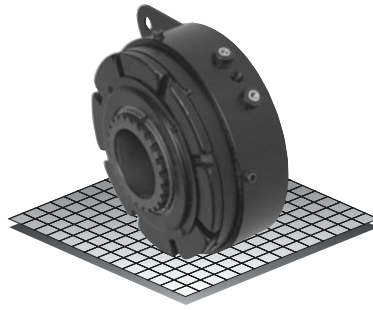

- ▶ Factory Assembled and Tested
- ▶ Bearing Mounted
- ▶ Replaceable Face
- ▶ Spline Drive

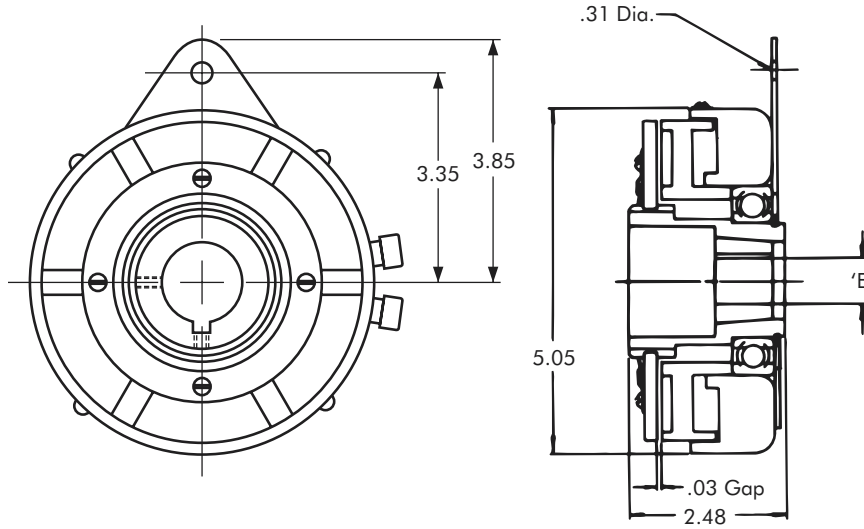

Bushing 1008

Bore 'E'		Keyway	Part No.
1/2"	.500	.125 x .062	326244 - 4
9/16"	.562	.125 x .062	326244 - 5
5/8"	.625	.187 x .093	326244 - 6
11/16"	.687	.187 x .093	326244 - 7
3/4"	.750	.187 x .093	326244 - 1
13/16"	.812	.187 x .093	326244 - 8
7/8"	.875	.187 x .093	326244 - 2
15/16"	.937	.250 x .125	326244 - 9
1"	1.000	.250 x .125	326244 - 3

Technical Data and Torque (In. Lb.)

Model No.	Wt. Lbs.	Static Torque in. lb.	Max. Speed RPM	Coil Voltage vdc	* Rated Current amps	RPM									
						0	300	600	900	1200	1500	1800	2400	3000	3600
305	7	684	3600	90	.40	684	624	564	516	468	420	384	324	288	252

* Rated Current for 90v.

Refer to Section M for torque and heat dissipation curves.

Order Parts for Assembly No. FC305090

	Shaft Mounted Brake	Tapered Bushing (1008)
24 Volts	305090-3	326244-XX
90 Volts	305090-4	326244-XX

To order, specify: 1, shaft mounted brake of required voltage
1, bushing plus bore size.

For controls, see Section K.

Shaft Mounted Brake – Replacement Parts

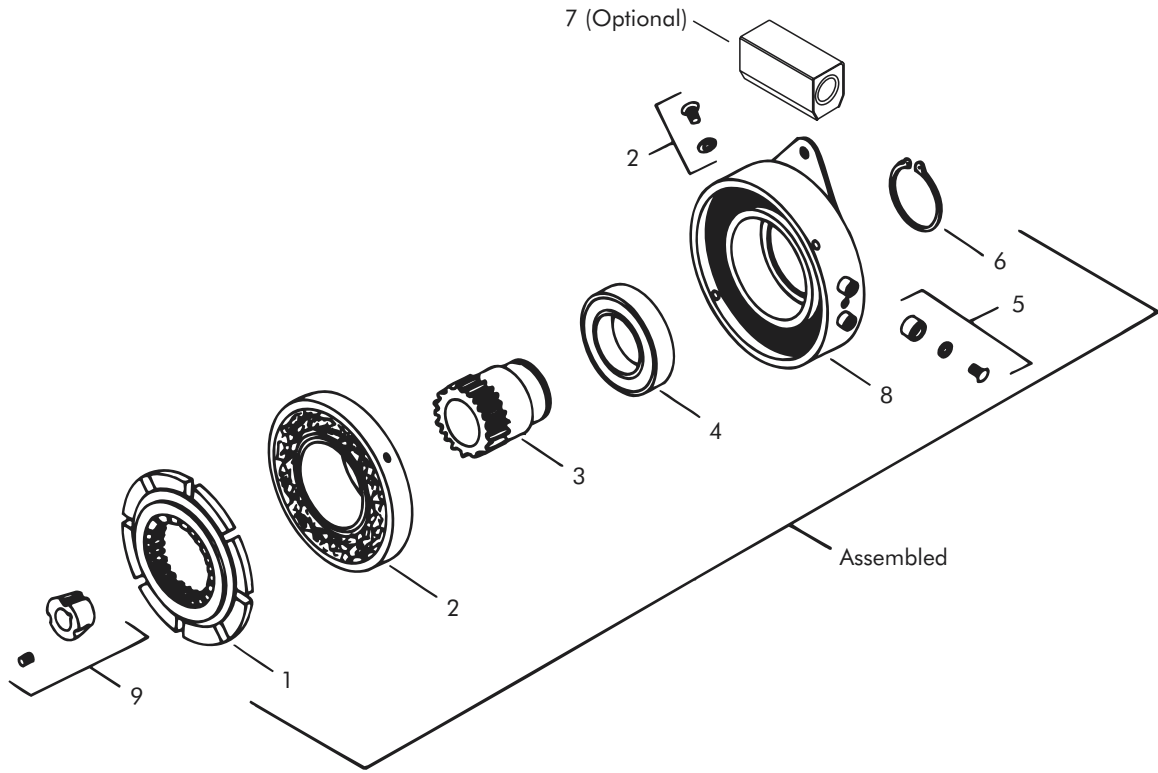

Replacement Parts

Item	Qty.	Description	Part No.	Item	Qty.	Description	Part No.
1	1	Armature Assembly	305396-1	8	1	Magnet 24 Volts 90 Volts	305333-3 305334-3
2	1	Replaceable Face Assembly	305561				
3	1	Armature Hub	305454-27				
4	1	Bearing	DY-6953	9	1	Taper Bushing (1008)	326244-XX
5	1	Terminal Accessory	326146-1	10	1	Torque Arm Kit (Opt.) (not shown)	327046
6	1	Retaining Ring (External)	DY12712				
7	1	Conduit Box (Optional)	326143				

See Page E-12 for information on Torque Arm Kit.