

Foot Mounted Clutch-Brake Package

Model

● CBP-400



- ▶ Factory Assembled and Tested
- ▶ Spline Drive

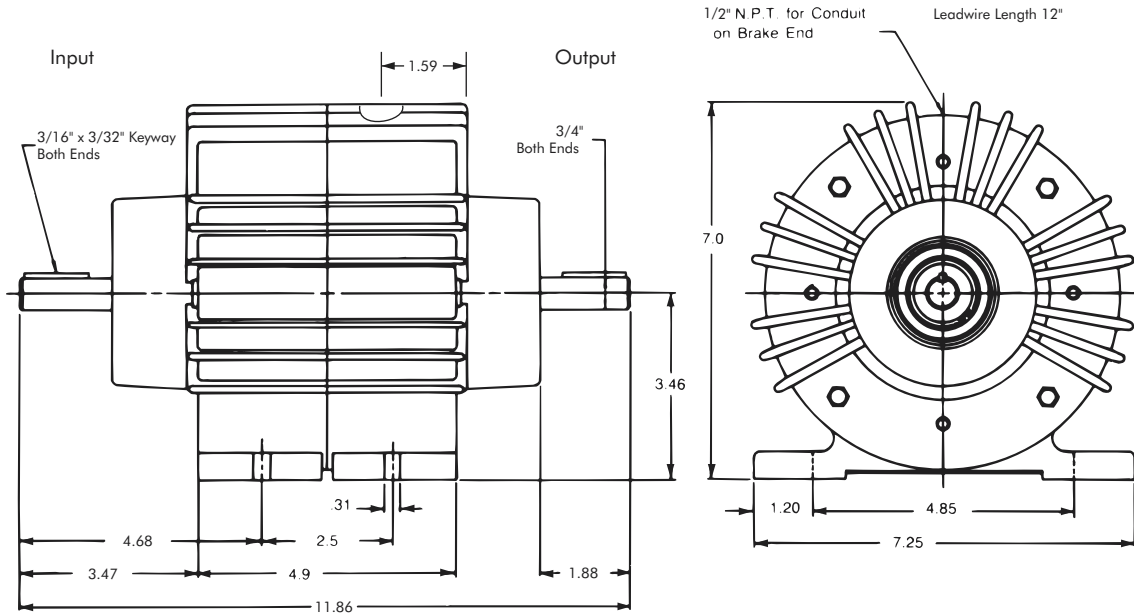

Technical Data and Torque (In. Lb.)

Model No.	Wt. Lbs.	Static Torque in. lb.	Max. Speed RPM	Coil Voltage vdc	* Rated Current amps	RPM									
						0	300	600	900	1200	1500	1800	2400	3000	3600
CBP-400	23	264	3600	90	.12	264	216	192	180	168	156	156	144	132	120

Refer to Section M for torque and heat dissipation curves.

* Rated Current for 90v.

	Model No.
	CBP-400
24 Volts	304184-7
90 Volts	304184-8

To order use number shown in Table above.
For controls, see Section K.

Foot Mounted Clutch-Brake Package – Replacement Parts

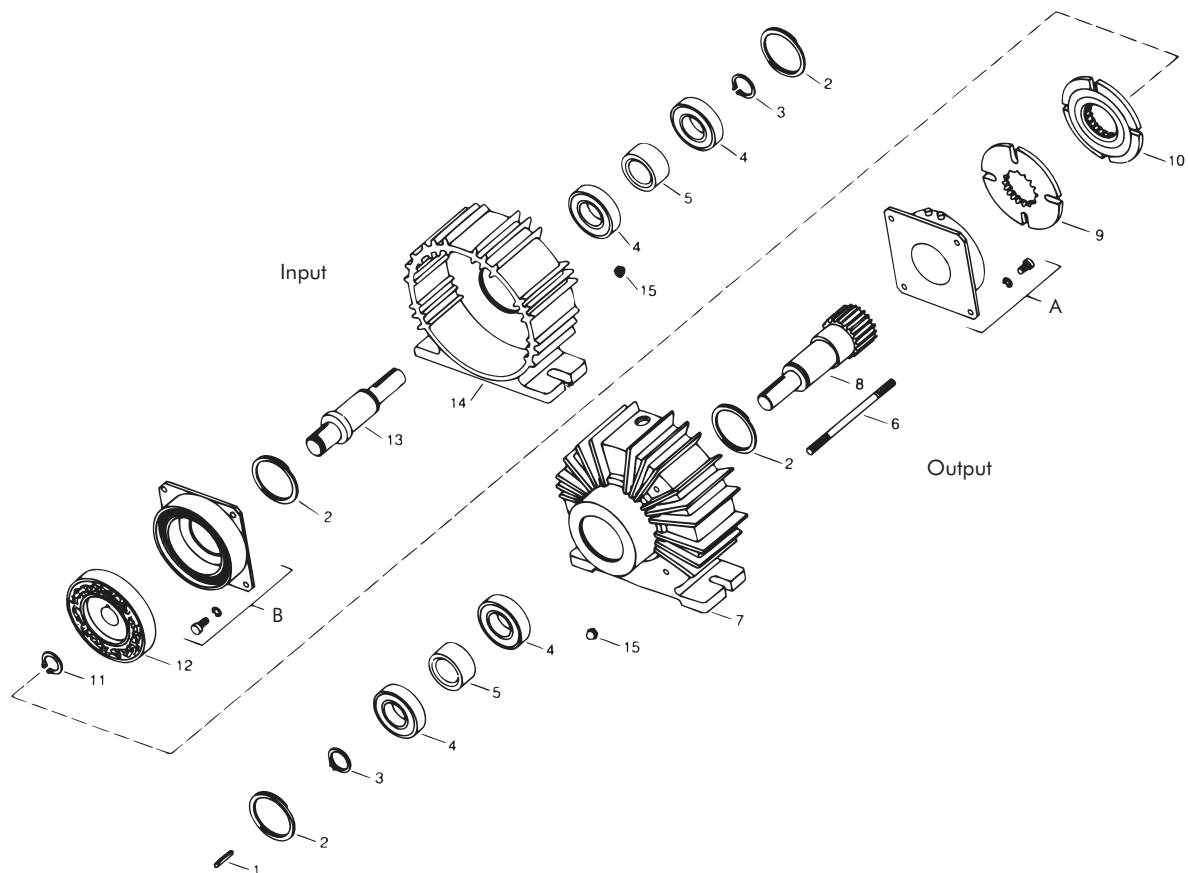

Replacement Parts

Item	Qty.	Description	Part No.	Item	Qty.	Description	Part No.
1	3	Key	DY-6529	15	8	Acorn Nuts	RY-20051
2	4	Retaining Ring	DY-10860	16	2	Magnet Accessory (not shown)	326146-2
3	2	Retaining Ring	DY-1102	17	2	Screw (not shown)	DY-497
4	4	Bearing	DY-11500	A	1	Magnet (Brake)*	
5	2	Bearing Spacer	326629			24 Volts	304353-16
6	4	Assembly Stud	626647			90 Volts	304354-16
7	1	Brake End Cap	650349-1	B	1	Field (Clutch)	
8	1	Splined Shaft	650340-3			24 Volts	304323
9	2	Armature Plate	304396-8			90 Volts	304324
11	1	Retaining Ring	RY-20033				
12	1	Rotor	304526-6				
13	1	Shaft	650348				
14	1	Clutch End Cap	650349-2				

* Units manufactured after April 2003 have -16 brake fields. Prior to that date, remove -16 from part number of brake field for service part.