

Flange Mounted Brake

Model

● 310

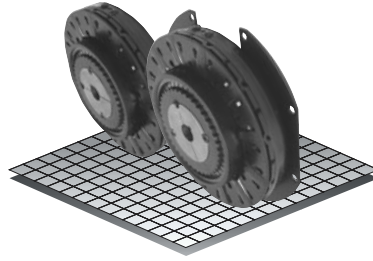

- ▶ Flange Mounted
- ▶ Spline Drive

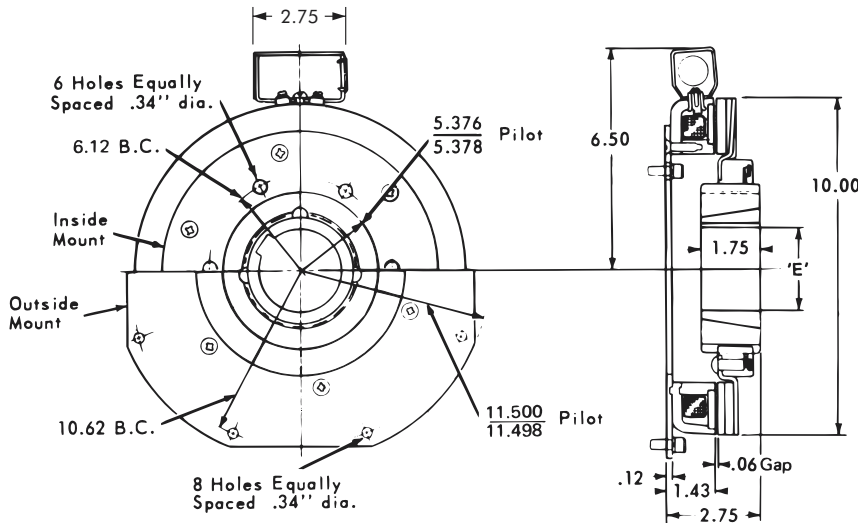

Bushing 2517

Bore 'E'	Keyway	Part No.
1/2"	.500 .125 x .062	326039 - 1
9/16"	.562 .125 x .062	326039 - 2
5/8"	.625 .187 x .093	326039 - 3
11/16"	.687 .187 x .093	326039 - 4
3/4"	.750 .187 x .093	326039 - 5
13/16"	.812 .187 x .093	326039 - 6
7/8"	.875 .187 x .093	326039 - 7
15/16"	.937 .250 x .125	326039 - 8
1"	1.000 .250 x .125	326039 - 9
1-1/16"	1.062 .250 x .125	326039 - 10
1-1/8"	1.125 .250 x .125	326039 - 11
1-3/16"	1.187 .250 x .125	326039 - 12
1-1/4"	1.250 .250 x .125	326039 - 13
1-5/16"	1.312 .312 x .156	326039 - 14
1-3/8"	1.375 .312 x .156	326039 - 15
1-7/16"	1.437 .375 x .187	326039 - 16
1-1/2"	1.500 .375 x .187	326039 - 17
1-9/16"	1.562 .375 x .187	326039 - 18
1-5/8"	1.625 .375 x .187	326039 - 19
1-11/16"	1.687 .375 x .187	326039 - 20
1-3/4"	1.750 .375 x .187	326039 - 21
1-13/16"	1.812 .500 x .250	326039 - 22
1-7/8"	1.875 .500 x .250	326039 - 23
1-15/16"	1.937 .500 x .250	326039 - 24
2"	2.000 .500 x .250	326039 - 25
2-1/16"	2.062 .500 x .250	326039 - 26
2-1/8"	2.125 .500 x .250	326039 - 27
2-3/16"	2.187 .500 x .250	326039 - 28
2-1/4"	2.250 .500 x .250	326039 - 29
2-5/16"	2.312 .625 x .187	326039 - 30
2-3/8"	2.375 .625 x .187	326039 - 31
2-7/16"	2.437 .625 x .187	326039 - 32
2-1/2"	2.500 .625 x .187	326039 - 33

Technical Data and Torque (In. Lb.)

Model No.	Wt. Lbs.	Static Torque in. lb.	Max. Speed RPM	Coil Voltage vdc	* Rated Current amps	RPM							
						0	300	600	900	1200	1500	1800	2400
310	25.1	3600	2400	90	.60	3600	3144	2616	2088	1788	1596	1416	1044

* Rated current at 90v.

Customer must maintain:

1. Concentricity between mounting flange and shaft within .010.
2. Perpendicularity between mounting surface and shaft within .010.

Refer to Section M for torque and heat dissipation curves.

Order Parts for Assembly No. FC310054 and FC310055

	Armature Hub	Armature Plate Assembly	Magnet Accessory	(2517) Taper Bushing	FC310054	FC310055	Magnet
					Mounting Plate with Accessory		
					Inside Mounted	Outside Mounted	
24 Volts	310680	310383-13	326078	326039-XX	310481	310491	310373
90 Volts	310680	310383-13	326078	326039-XX	310481	310491	310374

To order, specify:

- 1, Armature Hub
- 1, Armature Plate Assembly
- 1, Magnet Accessory
- 1, Taper Bushing (2517) of required Bore size
- 1, Mounting Plate with Accessory for either Inside Mount or Outside Mount
- 1, Magnet of required Voltage

For controls, see Section K.

Flange Mounted Brake – Replacement Parts

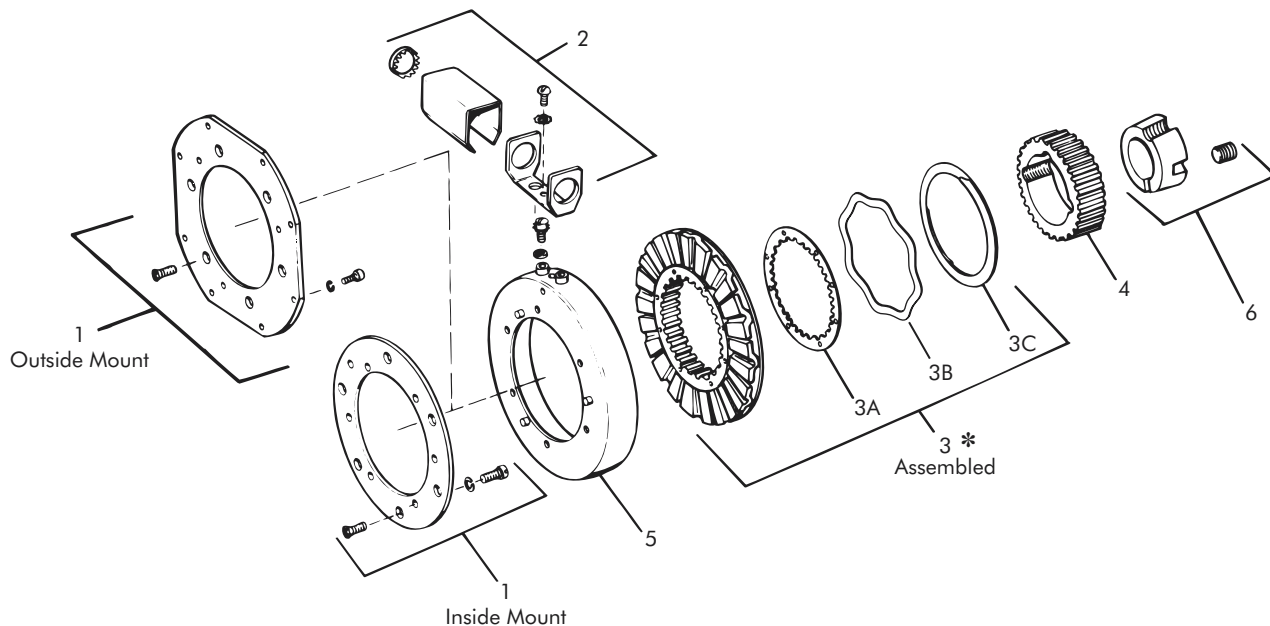

Replacement Parts

Item	Qty.	Description	Part No.	Item	Qty.	Description	Part No.
1	1	Mounting Plate w/Accessory Inside Mounting Outside Mounting	310481 310491	4	1	Armature Hub	310680
2	1	Magnet Accessory	326078	5	1	Magnet 24 Volts 90 Volts	310373 310374
3	1	Armature Plate Assy. (39 Teeth)	310383-13	6	1	Taper Bushing (2517)	326039-XX
3-A	1	Drag Spring	326277				
3-B	1	Ajusto-gap® Spring	326970				
3-C	1	Retaining Ring	RY-20317				

* Current design armatures are solid.