

Flange Mounted Brake

Model

● 310

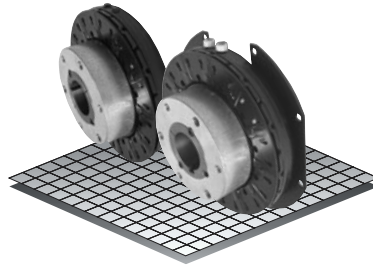

▶ Flange Mounted

▶ Pin Drive

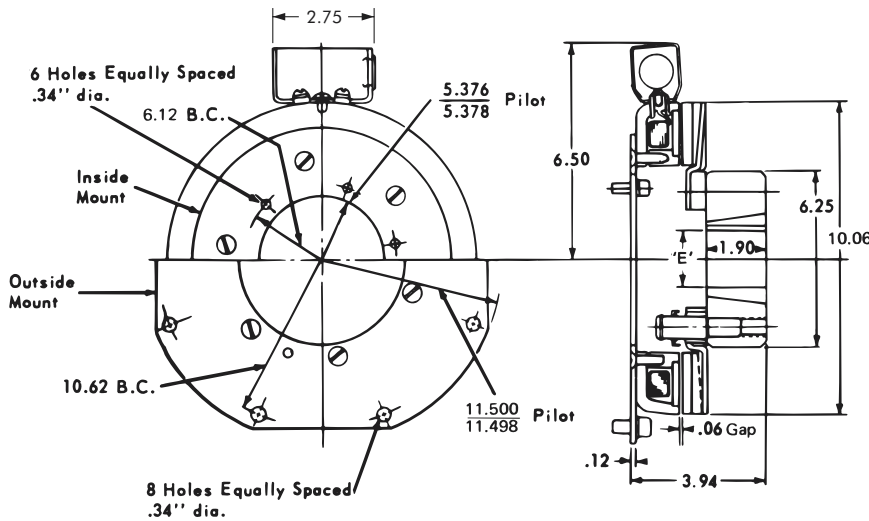

Bushing 2517

Bore 'E'	Keyway	Part No.
1/2"	.500 .125 x .062	326039 - 1
9/16"	.562 .125 x .062	326039 - 2
5/8"	.625 .187 x .093	326039 - 3
11/16"	.687 .187 x .093	326039 - 4
3/4"	.750 .187 x .093	326039 - 5
13/16"	.812 .187 x .093	326039 - 6
7/8"	.875 .187 x .093	326039 - 7
15/16"	.937 .250 x .125	326039 - 8
1"	1.000 .250 x .125	326039 - 9
1-1/16"	1.062 .250 x .125	326039 - 10
1-1/8"	1.125 .250 x .125	326039 - 11
1-3/16"	1.187 .250 x .125	326039 - 12
1-1/4"	1.250 .250 x .125	326039 - 13
1-5/16"	1.312 .312 x .156	326039 - 14
1-3/8"	1.375 .312 x .156	326039 - 15
1-7/16"	1.437 .375 x .187	326039 - 16
1-1/2"	1.500 .375 x .187	326039 - 17
1-9/16"	1.562 .375 x .187	326039 - 18
1-5/8"	1.625 .375 x .187	326039 - 19
1-11/16"	1.687 .375 x .187	326039 - 20
1-3/4"	1.750 .375 x .187	326039 - 21
1-13/16"	1.812 .500 x .250	326039 - 22
1-7/8"	1.875 .500 x .250	326039 - 23
1-15/16"	1.937 .500 x .250	326039 - 24
2"	2.000 .500 x .250	326039 - 25
2-1/16"	2.062 .500 x .250	326039 - 26
2-1/8"	2.125 .500 x .250	326039 - 27
2-3/16"	2.187 .500 x .250	326039 - 28
2-1/4"	2.250 .500 x .250	326039 - 29
2-5/16"	2.312 .625 x .187	326039 - 30
2-3/8"	2.375 .625 x .187	326039 - 31
2-7/16"	2.437 .625 x .187	326039 - 32
2-1/2"	2.500 .625 x .187	326039 - 33

Technical Data and Torque (In. Lb.)

Model No.	Wt. Lbs.	Static Torque in. lb.	Max. Speed RPM	Coil Voltage vdc	* Rated Current amps	RPM							
						0	300	600	900	1200	1500	1800	2400
310	26	3600	2400	90	.60	3600	3144	2616	2088	1788	1596	1416	1044

* Rated current at 90v.

Customer must maintain:

1. Concentricity between mounting flange and shaft within .010.

2. Perpendicularity between mounting surface and shaft within .010.

Refer to Section M for torque and heat dissipation curves.

Order Parts for Assembly No. FC310050 and FC310051

	Armature Hub	Armature Plate Assembly	Magnet Accessory	(2517) Taper Bushing	FC310050	FC310051	Magnet	Ajusto-gap® Accessory
					Mounting Plate with Access.			
					Inside Mounting	Outside Mounting		
24 Volts	310450	310380	326078	326039-XX	310481	310491	310373	326075
90 Volts	310450	310380	326078	326039-XX	310481	310491	310374	326075

To order, specify:

- 1, Armature Hub
- 1, Armature Plate Assembly
- 1, Magnet Accessory
- 1, Taper Bushing (2517) of required Bore size
- 1, Mounting Plate with Accessory for either Inside Mount or Outside Mount
- 1, Magnet of required Voltage
- 1, Ajusto-gap® Accessory

For controls, see Section K.

Flange Mounted Brake – Replacement Parts

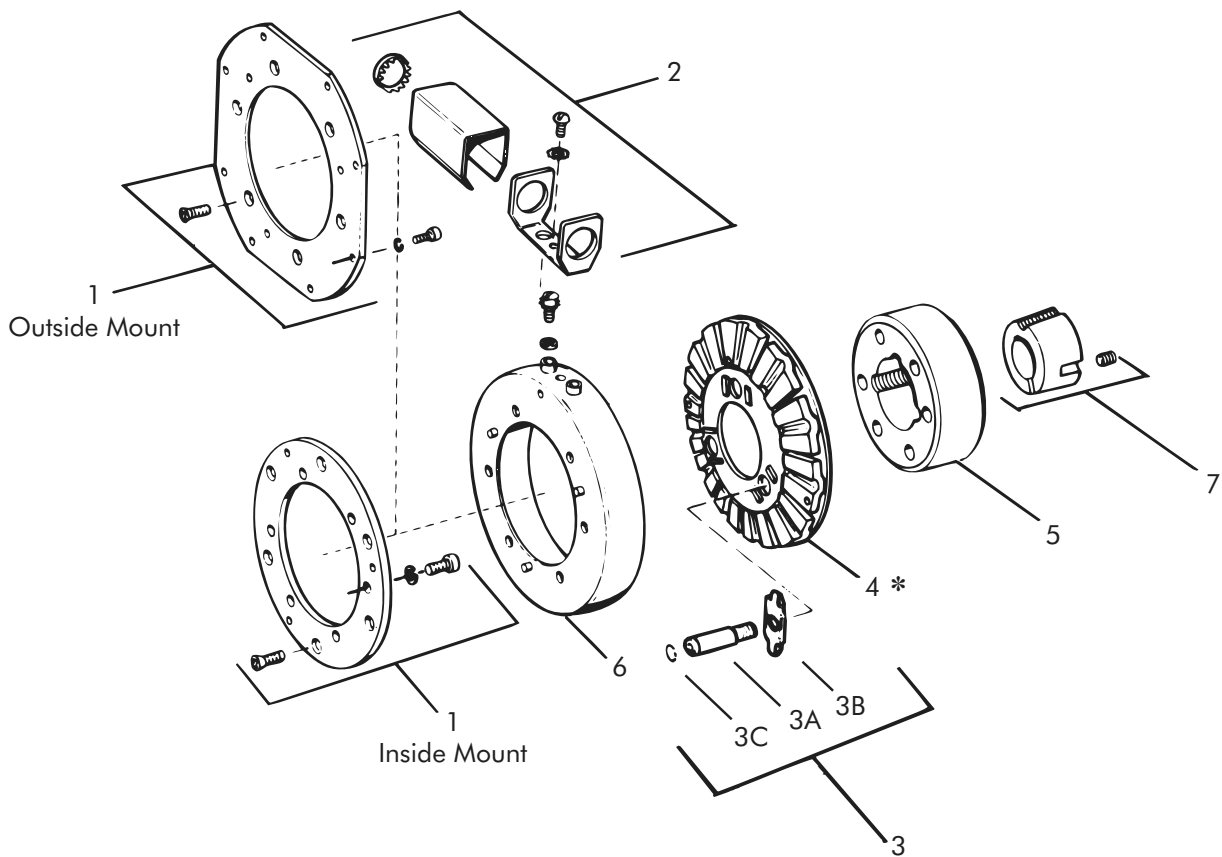

Replacement Parts

Item	Qty.	Description	Part No.	Item	Qty.	Description	Part No.
1	1	Mounting Plate w/Accessory Inside Mounting Outside Mounting	310481 310491	4	1	Armature Plate Assembly	310380
2	1	Magnet Accessory	326078	5	1	Armature Hub	310450
3	1	Ajusto-gap® Accessory	326075	6	1	Magnet 24 Volts	310373
3-A	3	Drive Pin	326008	7	1	90 Volts Taper Bushing (2517)	310374 326039-XX
3-B	3	Spring	326149				
3-C	3	Retaining Ring	DY-10572				

* Current design armatures are solid.