

Flange Mounted Brakes

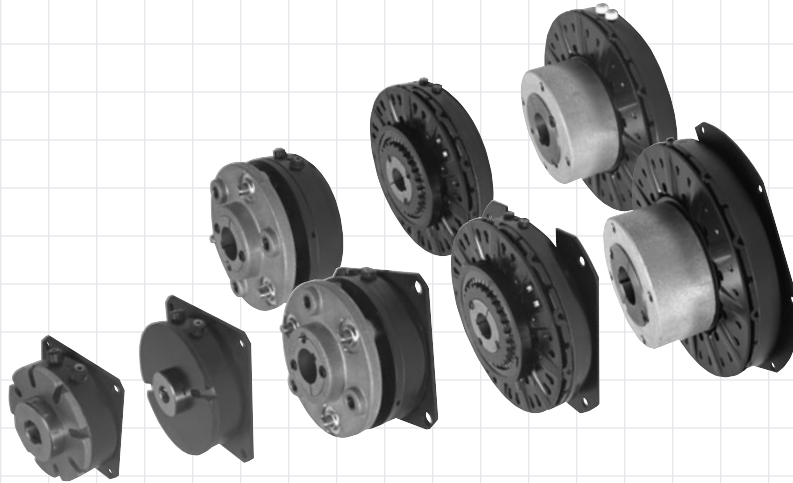

Description

Dynacorp® flange mounted brakes satisfy a wide range of stopping requirements. The 3" and 4" brakes have an outside mounting flange, while the 5" through 10" brakes are available with an inside or outside mounting flange.

Section Index

Products Complete information is shown for each product; including specifications, drawings, dimensions, parts list, recommended controls and information for ordering.

Model	Nominal Size	Style	Static Torque (In.-Lbs.)	Maximum HP @ 1800 RPM	Page
303	3 inch	Spline Drive	60	1/2	H-2
304	4 inch	Spline Drive	264	2	H-4
305	5 inch	Pin Drive	684	7-1/2	H-6
305	5 inch	Spline Drive	684	7-1/2	H-8
308	8 inch	Pin Drive	2100	30	H-10
308	8 inch	Spline Drive	2100	30	H-12
310	10 inch	Pin Drive	3600	40	H-14
310	10 inch	Spline Drive	3600	40	H-16

Ajusto-Gap® Armature and Hub Assembly	H-18
Terminal Insulating Kit	H-19
Zero Air Gap Accessory Kit	H-20

Flange Mounted Brake

Model

● 303

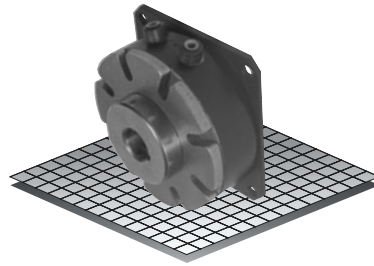

▶ Flange Mounted
▶ Spline Drive

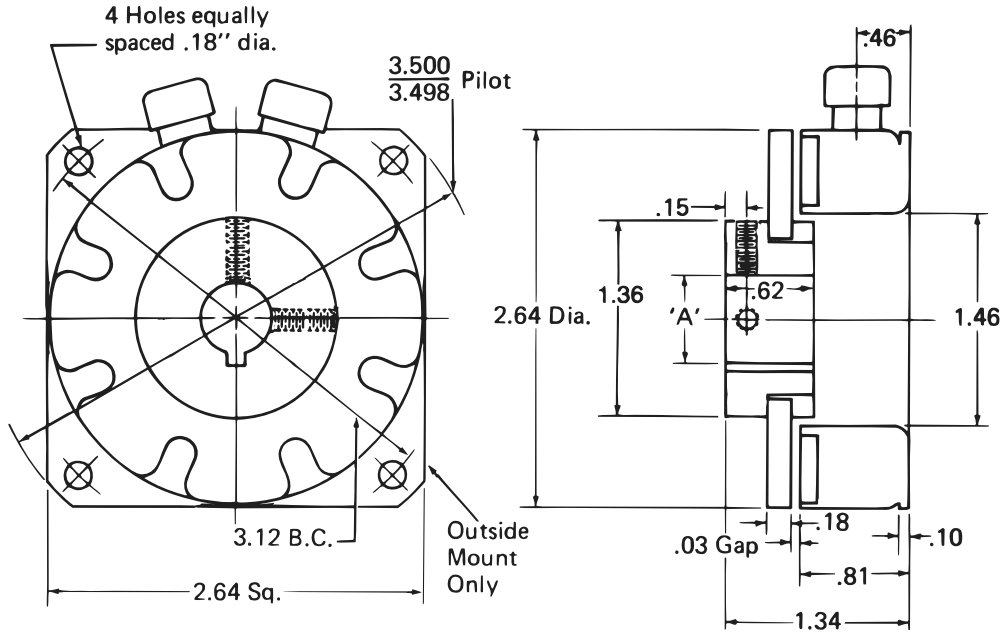

"A" Bore	Keyway
1/2"	.125 x .062
5/8"	.188 x .093
3/4"	.188 x .093

Technical Data and Torque (In. Lb.)

Model No.	Wt. Lbs.	Static Torque in. lb.	Max. Speed RPM	Coil Voltage vdc	* Rated Current amps	RPM									
						0	300	600	900	1200	1500	1800	2400	3000	3600
303	.71	60	3600	90	.11	60	53	48	43	42	41	38	35	32	30

* Rated current for 90v.

Customer must maintain:

1. Concentricity between mounting flange and shaft within .006.
2. Perpendicularity between mounting surface and shaft within .006.

Refer to Section M for torque and heat dissipation curves.

Order Parts for Assembly No. FC303055

	Armature Plate	Magnet Accessory	Armature Hub Assembly			Magnet
			Bore			
			1/2"	5/8"	3/4"	
24 Volts	303390-2	326147	303451-3	303451-5	303453-8	303353
90 Volts	303390-2	326147	303451-3	303451-5	303453-8	303354

To order, specify: 1, Armature Plate
1, Magnet Accessory
1, Armature Hub Assembly of required Bore size
1, Magnet of required Voltage

For controls, see Section K.

Flange Mounted Brake – Replacement Parts

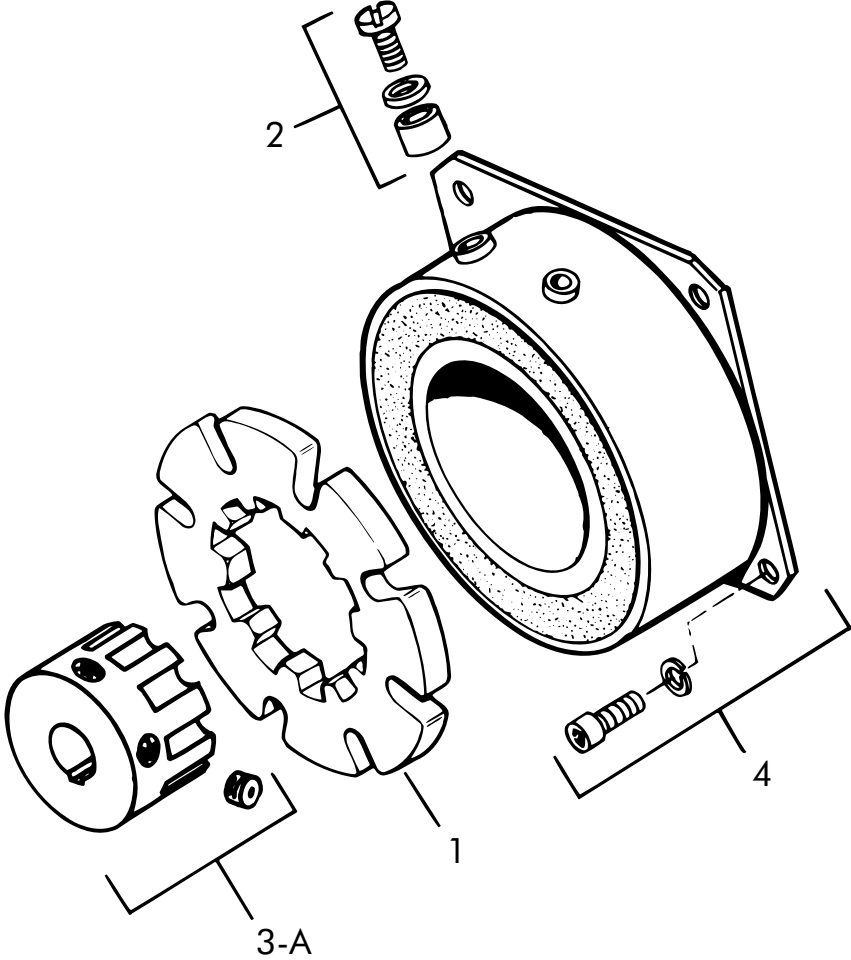

Replacement Parts

Item	Qty.	Description	Part No.	Item	Qty.	Description	Part No.
1	1	Armature Plate Assy. (10 Teeth)	303390-2	4	1	Magnet	
2	1	Magnet Accessory	326147			24 Volts	303353
3-A	1	Armature Hub Assembly				90 Volts	303354
		3/8" Plain Bore	303453-PB				
		1/2" Bore	303451-3				
		5/8" Bore	303451-5				
		3/4" Bore	303453-8				

Flange Mounted Brake

Model

● 304

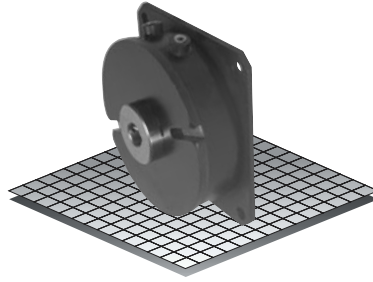

▶ Flange Mounted
▶ Spline Drive

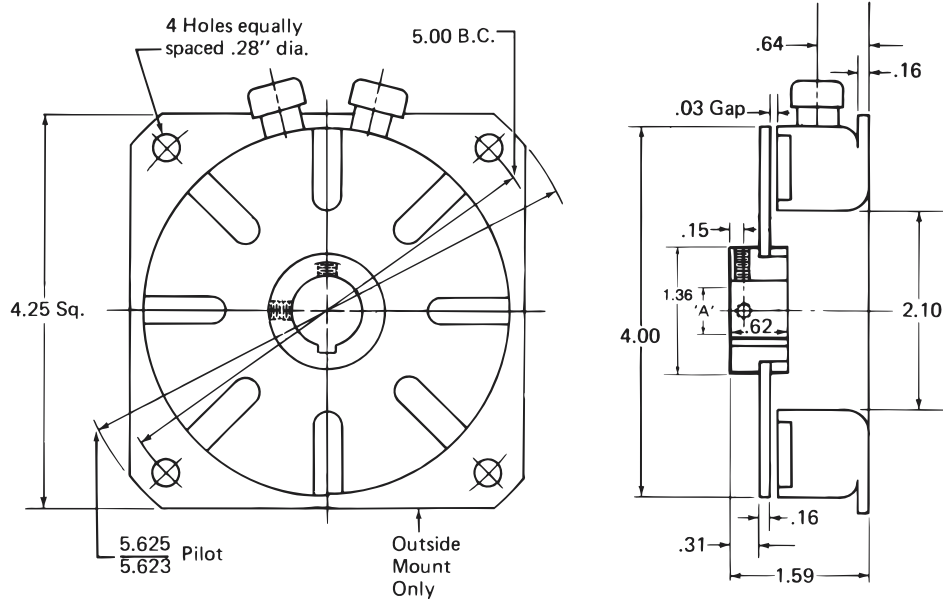

Bore "A"	Keyway
1/2"	.125 x .062
5/8"	.187 x .094
3/4"	.187 x .094
7/8"	.187 x .094
1"	.250 x .125

Technical Data and Torque (In. Lb.)

Model No.	Wt. Lbs.	Static Torque in. lb.	Max. Speed RPM	Coil Voltage vdc	* Rated Current amps	RPM									
						0	300	600	900	1200	1500	1800	2400	3000	3600
304	2.5	264	3600	90	.13	264	216	192	180	168	156	156	144	132	120

* Rated current at 90v.

Customer must maintain:

1. Concentricity between mounting flange and shaft within .006.
2. Perpendicularity between mounting surface and shaft within .006.

Refer to Section M for torque and heat dissipation curves.

Refer to Page H-18 for dimensions of Ajusto-gap®.

Order Parts for Assembly No. FC304055

	Armature Plate	Accessory	Armature Hub Assembly Magnet			Bore Magnet
			1/2"	5/8"	3/4"	
24 Volts	304390-11	326146-2	303451-3	303451-5	303453-8	304353
90 Volts	304390-11	326146-2	303451-3	303451-5	303453-8	304354

To order, specify: 1, Armature Plate
1, Magnet Accessory
1, Armature Hub Assembly of required Bore size
1, Magnet of required Voltage

For controls, see Section K.

Flange Mounted Brake – Replacement Parts

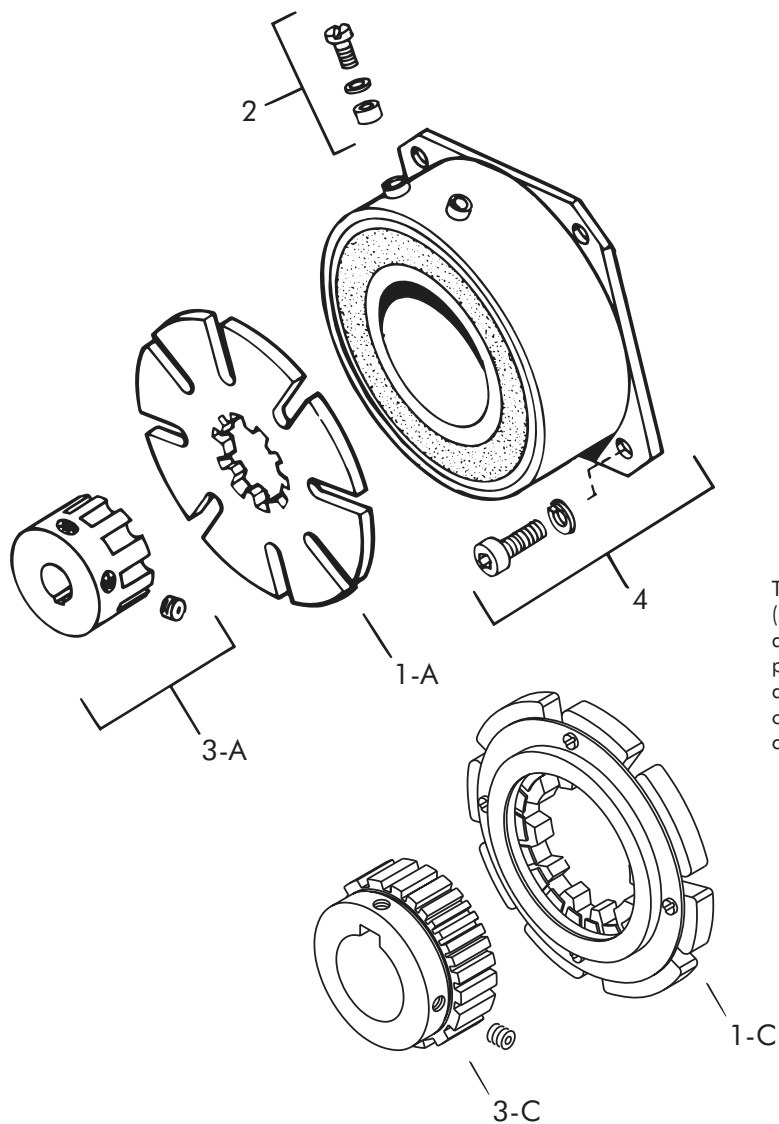

The Ajusto-gap® armature feature (1-C & 3-C) can be used to give a positive release of the armature plate while maintaining a constant air gap throughout the wear life of the unit. See page H-18 for complete information.

Replacement Parts

Item	Qty.	Description	Part No.	Item	Qty.	Description	Part No.
1-A	1	Armature Plate Assembly 10 Teeth (1/2" - 3/4" Bore)	304390-11	3-C	1	Ajusto-gap® Hub Assembly 7/8"	304465-4
1-C	1	Ajusto-gap® Arm. Plate Assy. 7/8" and 1" bores	304396-8	1"			304465-5
2	1	Magnet Accessory	326146-2	4	1	Magnet 24 Volts	304353
3-A	1	Armature Hub Assembly 1/2" Bore	303451-3	90 Volts			304354
		5/8" Bore	303451-5				
		3/4" Bore	303453-8				

Flange Mounted Brake

Model

● 305

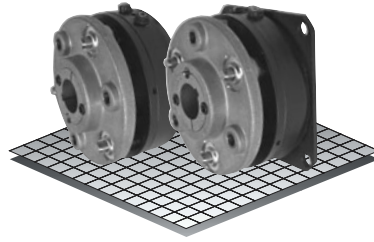

▶ Flange Mounted
▶ Pin Drive

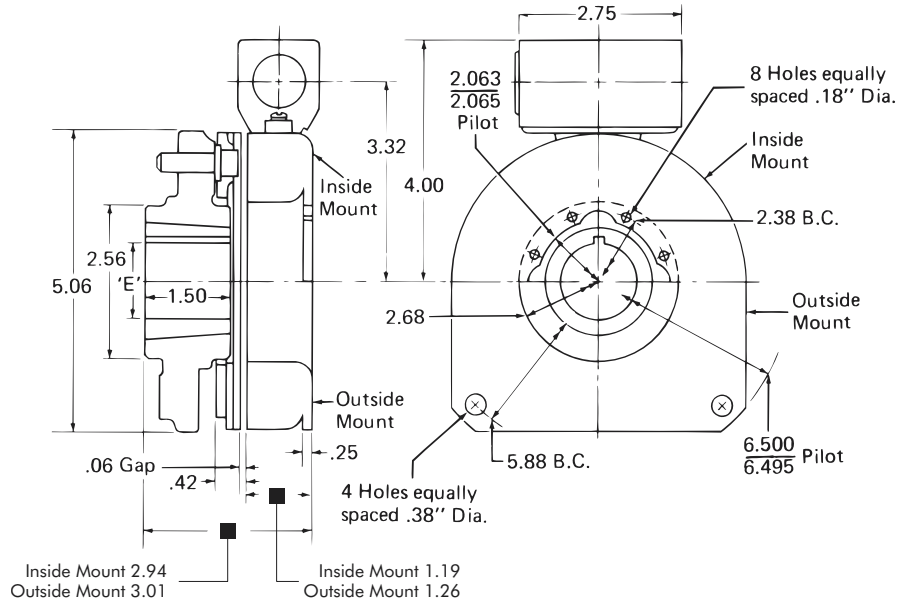

Bushing 1215

Bore 'E'		Keyway	Part No.
1/2"	.500	.125 x .062	326058 - 1
9/16"	.562	.125 x .062	326058 - 2
5/8"	.625	.187 x .093	326058 - 3
11/16"	.687	.187 x .093	326058 - 4
3/4"	.750	.187 x .093	326058 - 5
13/16"	.812	.187 x .093	326058 - 6
7/8"	.875	.187 x .093	326058 - 7
15/16"	.937	.250 x .125	326058 - 8
1"	1.000	.250 x .125	326058 - 9
1-1/16"	1.062	.250 x .125	326058 - 10
1-1/8"	1.125	.250 x .125	326058 - 11
1-3/16"	1.187	.250 x .125	326058 - 12
1-1/4"	1.250	.250 x .125	326058 - 13

Technical Data and Torque (In. Lb.)

Model No.	Wt. Lbs.	Static Torque in. lb.	Max. Speed RPM	Coil Voltage vdc	* Rated Current amps	RPM									
						0	300	600	900	1200	1500	1800	2400	3000	3600
305	3.5	684	3600	90	.41	684	624	564	516	468	420	384	324	288	252

* Rated current at 90v.

Refer to Section M for torque and heat dissipation curves.

Customer must maintain:

1. Concentricity between mounting flange and shaft within .006.
2. Perpendicularity between mounting surface and shaft within .006.

Order Parts for Assembly No. FC305050 and FC305051

	Armature Hub Assembly	Armature Plate Assembly	Magnet Accessory	(1215) Taper Bushing	FC305050	FC305051
					Magnet	
					Inside Mounted	Outside Mounted
24 Volts	305450	305381	326143	326058-XX	305343	305353
90 Volts	305450	305381	326143	326058-XX	305344	305354

To order, specify:

- 1, Armature Hub
- 1, Armature Plate Assembly
- 1, Magnet Accessory
- 1, Taper Bushing (1215) of required Bore size
- 1, Magnet of required Voltage for either Inside Mount or Outside Mount

For controls, see Section K.

Flange Mounted Brake

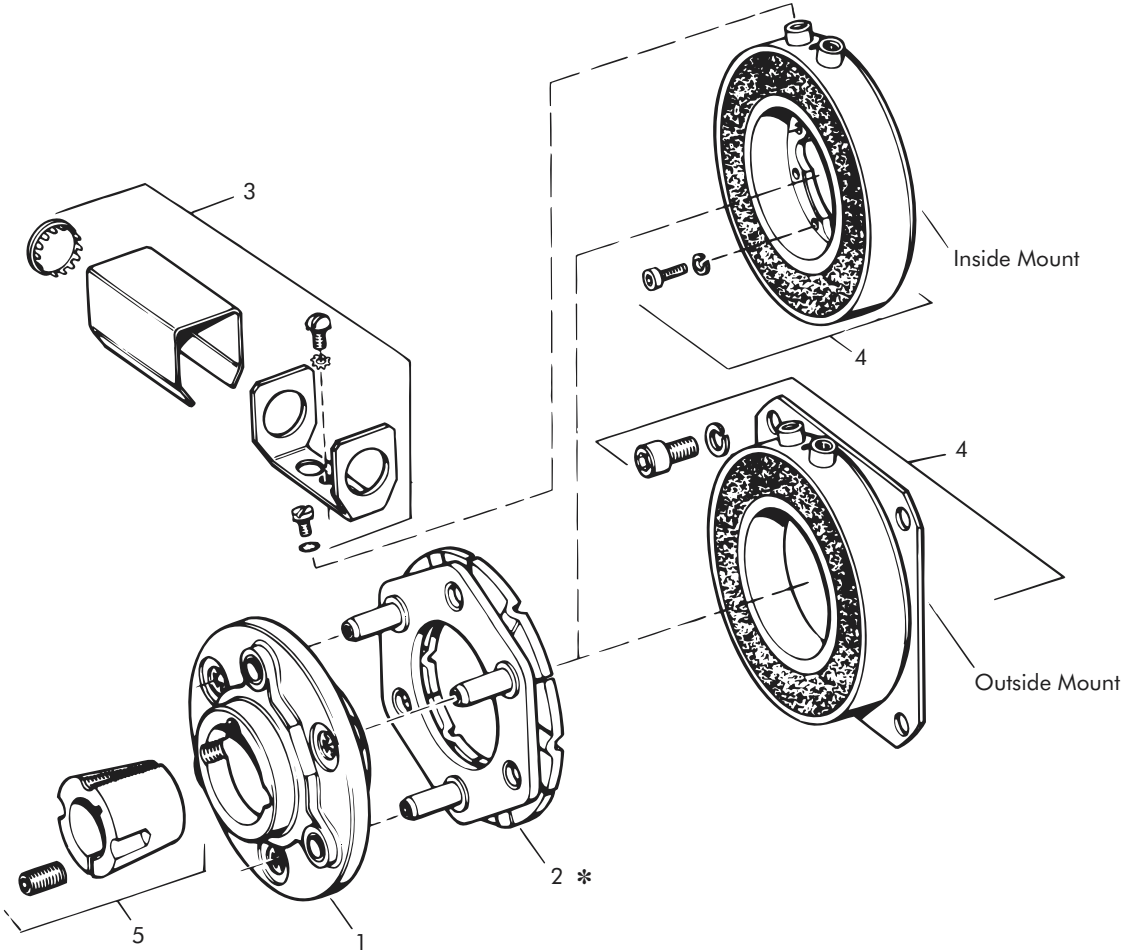

Replacement Parts

Item	Qty.	Description	Part No.
1	1	Armature Hub Assembly	305450
2	1	Armature Plate Assembly	305381
3	1	Magnet Accessory	326143
4	1	Magnet	
		24 Volts, inside mounted	305343
		90 Volts, inside mounted	305344
		24 Volts, outside mounted	305353
		90 Volts, outside mounted	305354
5	1	Taper Bushing (1215)	326058-XX

* Current design armatures are solid.

Flange Mounted Brake

Model

● 305



▶ Flange Mounted
▶ Spline Drive

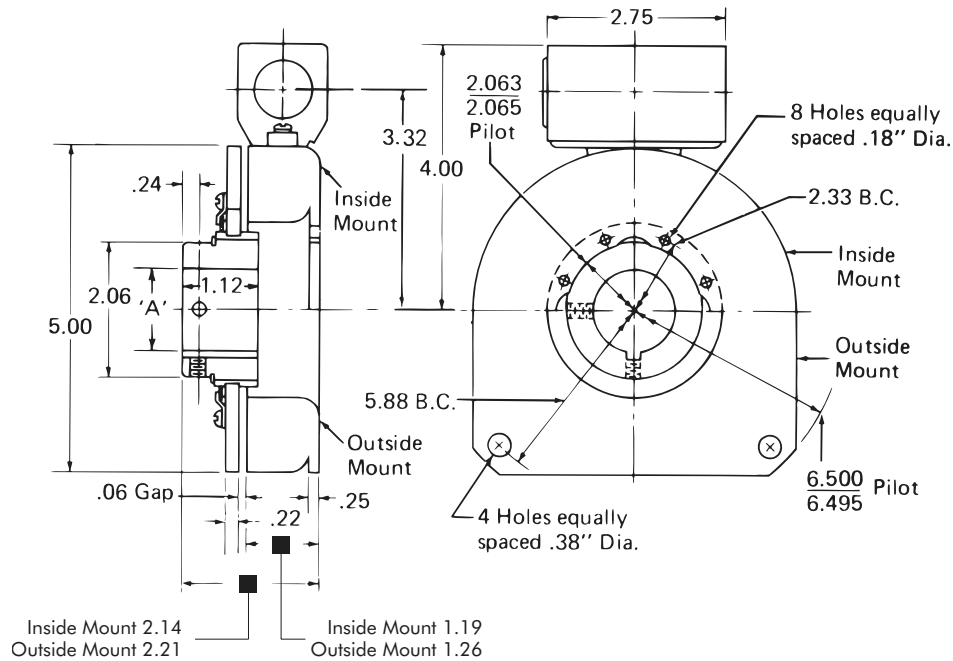

Bore "A"	Keyway
3/4"	.187 x .094
7/8"	.187 x .094
1"	.250 x .125
1-1/8"	.250 x .125
1-1/4"	.250 x .125

Technical Data and Torque (In. Lb.)

Model No.	Wt. Lbs.	Static Torque in. lb.	Max. Speed RPM	Coil Voltage vdc	* Rated Current amps	RPM									
						0	300	600	900	1200	1500	1800	2400	3000	3600
305	5.1	684	3600	90	.41	684	624	564	516	468	420	384	324	288	252

* Rated current at 90v.

Customer must maintain:

1. Concentricity between mounting flange and shaft within .010.
2. Perpendicularity between mounting surface and shaft within .010.

Refer to Section M for torque and heat dissipation curves.

Order Parts for Assembly No. FC305054 and FC305055

	Armature Plate Assembly	Magnet Accessory	Armature Hub Assembly					FC305054		FC305055	
			Bore					Magnet		Inside Mount	Outside Mount
			3/4"	7/8"	1"	1-1/8"	1-1/4"				
24 Volts	305396-1	326143	305453-1	305453-2	305453-3	305453-4	305453-5	305343	305353		
90 Volts	305396-1	326143	305453-1	305453-2	305453-3	305453-4	305453-5	305344	305354		

To order, specify: 1, Armature Plate Assembly
1, Magnet Accessory
1, Armature Hub Assembly of required Bore size
1, Magnet of required Voltage for either Inside Mount or Outside Mount

For controls, see Section K.

Flange Mounted Brake – Replacement Parts

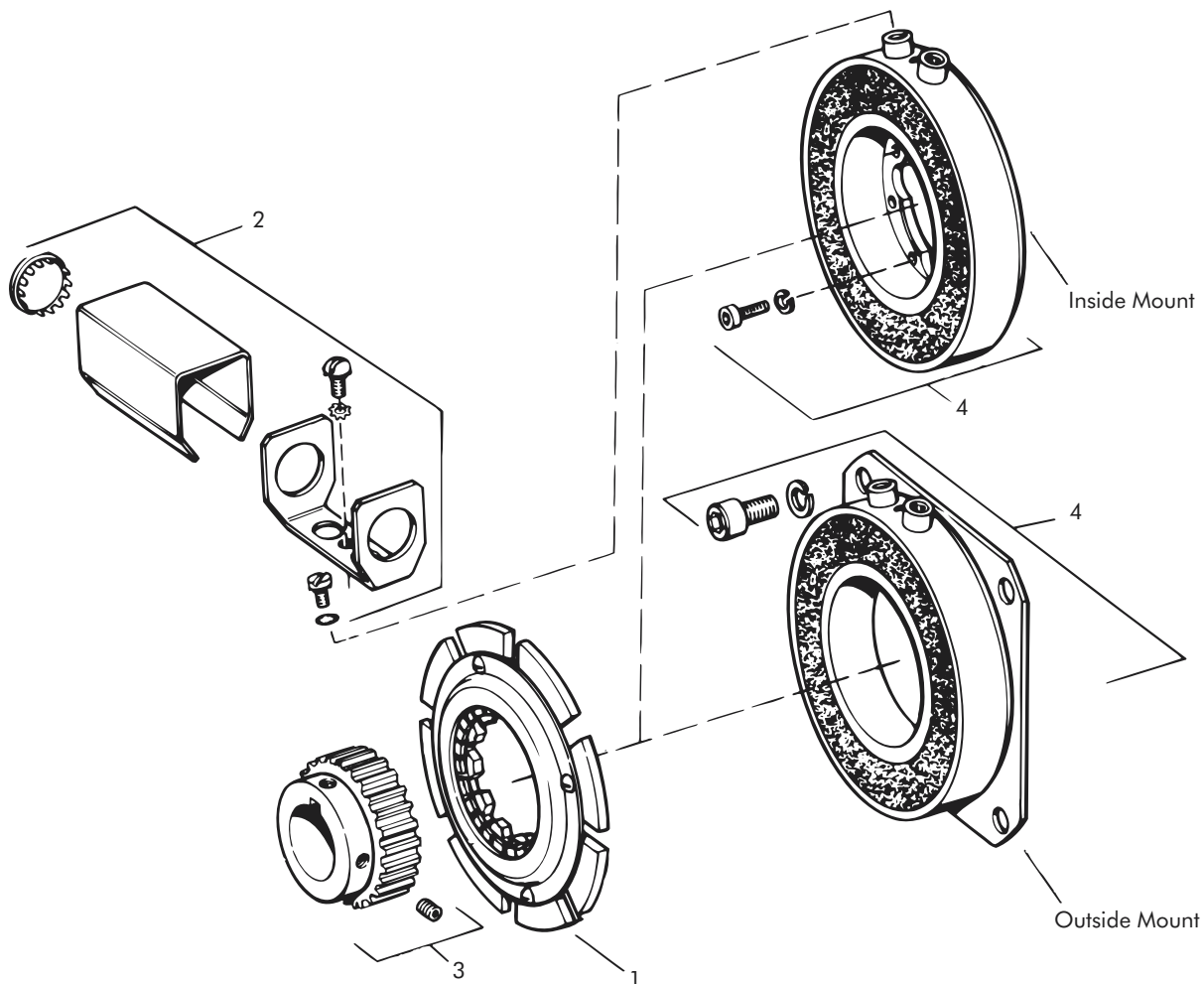

Replacement Parts

Item	Qty.	Description	Part No.	Item	Qty.	Description	Part No.
1	1	Armature Plate Assy. (24 Teeth)	305396-1	4	1	Magnet	
2	1	Magnet Accessory	326143			24 Volts, Inside mounted	305343
3	1	Armature Hub Assembly				90 Volts, Inside mounted	305344
		3/4" Bore	305453-1			24 Volts, Outside mounted	305353
		7/8" Bore	305453-2			90 Volts, Outside mounted	305354
		1" Bore	305453-3				
		1-1/8" Bore	305453-4				
		1-1/4" Bore	305453-5				

Flange Mounted Brake

Model

● 308

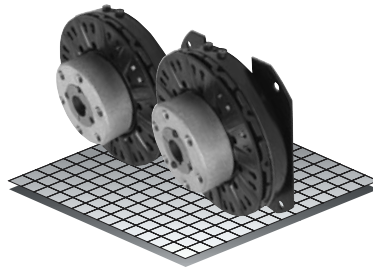

▶ Flange Mounted
▶ Pin Drive

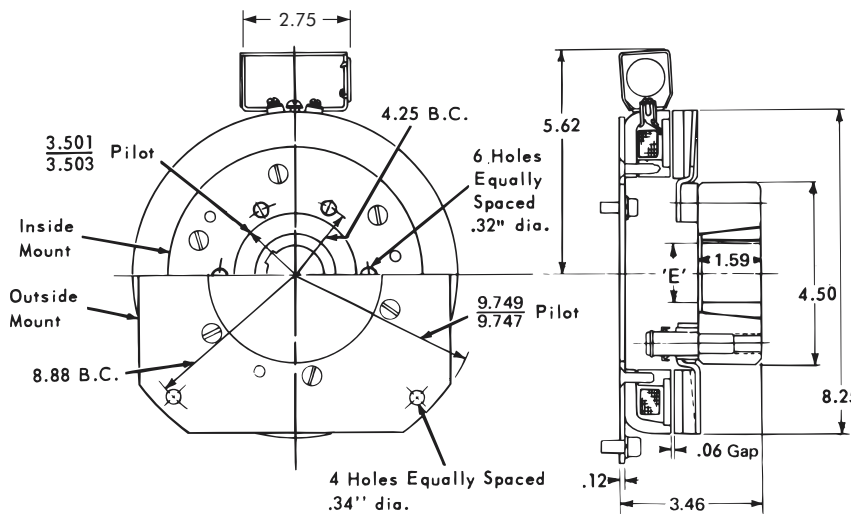

Bushing 1615

Bore 'E'	Keyway	Part No.
1/2"	.500 .125 x .062	326015 - 1
9/16"	.562 .125 x .062	326015 - 2
5/8"	.625 .187 x .093	326015 - 3
11/16"	.687 .187 x .093	326015 - 4
3/4"	.750 .187 x .093	326015 - 5
13/16"	.812 .187 x .093	326015 - 6
7/8"	.875 .187 x .093	326015 - 7
15/16"	.937 .250 x .125	326015 - 8
1"	1.000 .250 x .125	326015 - 9
1-1/16"	1.062 .250 x .125	326015 - 10
1-1/8"	1.125 .250 x .125	326015 - 11
1-3/16"	1.187 .250 x .125	326015 - 12
1-1/4"	1.250 .250 x .125	326015 - 13
1-5/16"	1.312 .312 x .156	326015 - 14
1-3/8"	1.375 .312 x .156	326015 - 15
1-7/16"	1.437 .375 x .187	326015 - 16
1-1/2"	1.500 .375 x .187	326015 - 17
1-9/16"	1.562 .375 x .187	326015 - 18
1-5/8"	1.625 .375 x .187	326015 - 19
*1-3/8"	1.375 .375 x .125	326015 - 20
*1-5/8"	1.625 .375 x .125	326015 - 21

Technical Data and Torque (In. Lb.)

Model No.	Wt. Lbs.	Static Torque in. lb.	Max. Speed RPM	Coil Voltage vdc	* Rated Current amps	RPM									
						0	300	600	900	1200	1500	1800	2400	3000	3600
308	16.4	2100	3600	90	.57	2100	1848	1596	1428	1344	1260	1128	888	720	588

* Rated current at 90v.

Customer must maintain:

1. Concentricity between mounting flange and shaft within .010.
2. Perpendicularity between mounting surface and shaft within .010.

Refer to Section M for torque and heat dissipation curves.

Order Parts for Assembly No. FC308050 and FC308051

	Armature Hub	Armature Plate Assembly	Magnet Accessory	(1615) Taper Bushing	FC308050	FC308051	Magnet	Ajusto-gap® Kit
					Mounting Plate with Accessory	Mounting Plate with Accessory		
					Inside Mounted	Outside Mounted		
24 Volts	308450	308380	326078	326015-XX	308481	308491	308373	326075
90 Volts	308450	308380	326078	326015-XX	308481	308491	308374	326075

To order, specify:

- 1, Armature Hub
- 1, Armature Plate Assembly
- 1, Magnet Accessory
- 1, Taper Bushing (1615) of required Bore size
- 1, Mounting Plate with Accessories for either Inside Mount or Outside Mount
- 1, Magnet of required Voltage
- 1, Ajusto-gap® Kit

For controls, see Section K.

Flange Mounted Brake – Replacement Parts

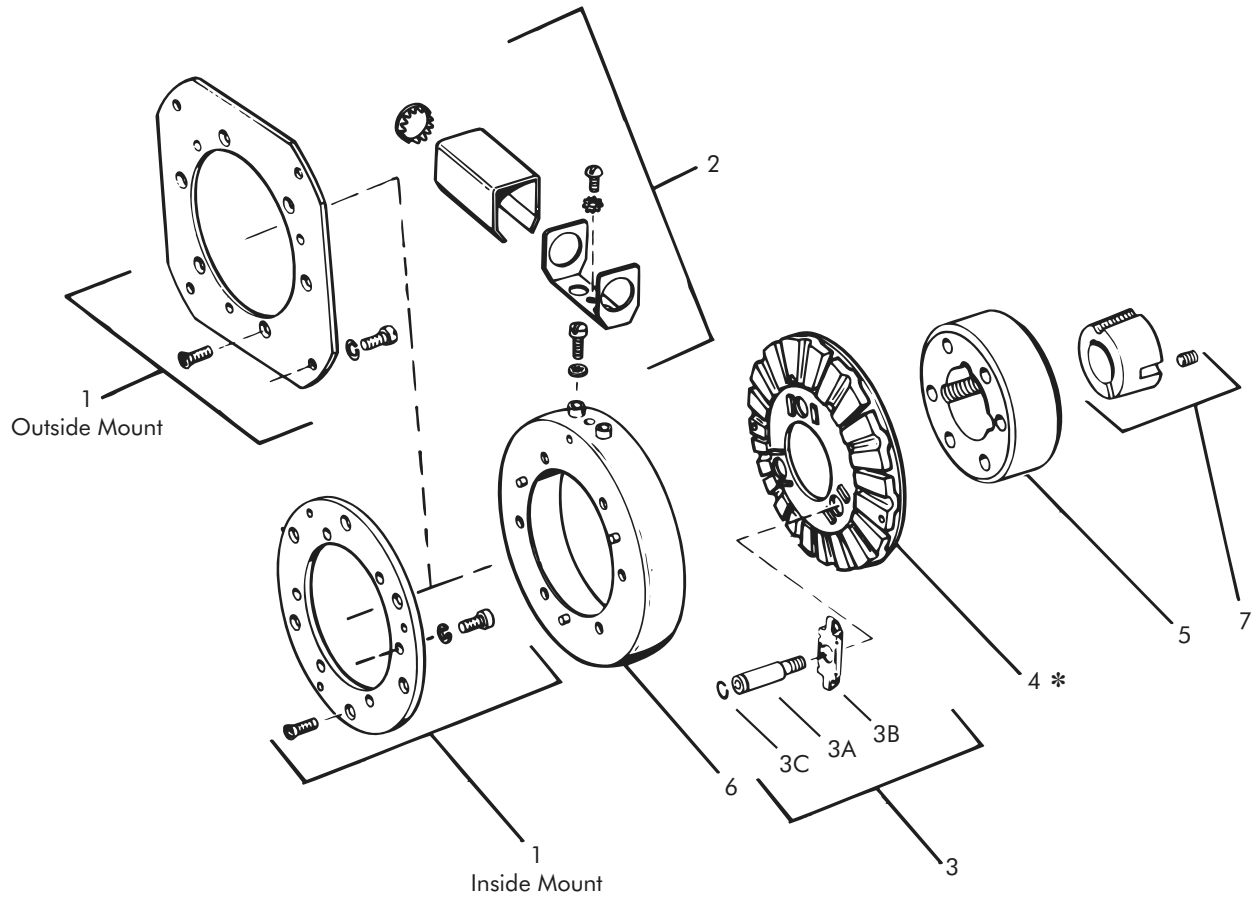

Replacement Parts

Item	Qty.	Description	Part No.	Item	Qty.	Description	Part No.
1	1	Mounting Plate w/Accessory		4	1	Armature Plate Assembly	308380
		Inside Mounting	308481	5	1	Armature Hub	308450
		Outside Mounting	308491	6	1	Magnet	
2	1	Magnet Accessory	326078			24 Volts	308373
3	1	Ajusto-gap® Kit	326075			90 Volts	308374
3-A	3	Drive Pin	326008	7	1	Taper Bushing (1615)	326015-XX
3-B	3	Spring	326149				
3-C	3	Retaining Ring	DY-10572				

* Current design armatures are solid.

Flange Mounted Brake

Model

● 308

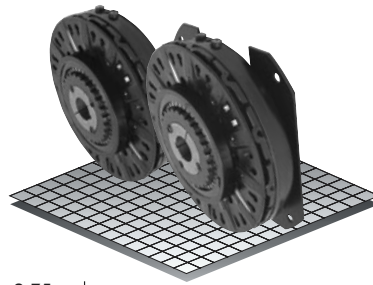

▶ Flange Mounted
▶ Spline Drive

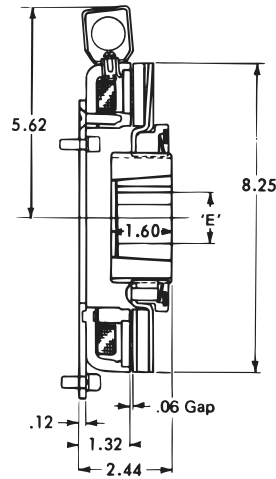
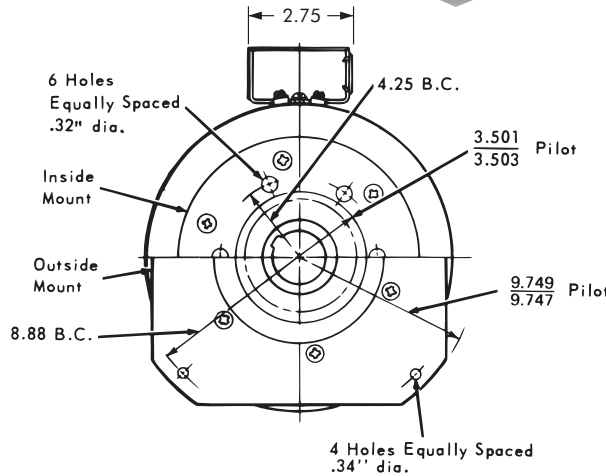

Bushing 1615

Bore 'E'		Keyway	Part No.
1/2"	.500	.125 x .062	326015 - 1
9/16"	.562	.125 x .062	326015 - 2
5/8"	.625	.187 x .093	326015 - 3
11/16"	.687	.187 x .093	326015 - 4
3/4"	.750	.187 x .093	326015 - 5
13/16"	.812	.187 x .093	326015 - 6
7/8"	.875	.187 x .093	326015 - 7
15/16"	.937	.250 x .125	326015 - 8
1"	1.000	.250 x .125	326015 - 9
1-1/16"	1.062	.250 x .125	326015 - 10
1-1/8"	1.125	.250 x .125	326015 - 11
1-3/16"	1.187	.250 x .125	326015 - 12
1-1/4"	1.250	.250 x .125	326015 - 13
1-5/16"	1.312	.312 x .156	326015 - 14
1-3/8"	1.375	.312 x .156	326015 - 15
1-7/16"	1.437	.375 x .187	326015 - 16
1-1/2"	1.500	.375 x .187	326015 - 17
1-9/16"	1.562	.375 x .187	326015 - 18
1-5/8"	1.625	.375 x .187	326015 - 19
*1-3/8"	1.375	.375 x .125	326015 - 20
*1-5/8"	1.625	.375 x .125	326015 - 21

Technical Data and Torque (In. Lb.)

Model No.	Wt. Lbs.	Static Torque in. lb.	Max. Speed RPM	Coil Voltage vdc	* Rated Current amps	RPM									
						0	300	600	900	1200	1500	1800	2400	3000	3600
308	16.4	2100	3600	90	.57	2100	1848	1596	1428	1344	1260	1128	888	720	588

* Rated current at 90v.

Refer to Section M for torque and heat dissipation curves.

Customer must maintain:

1. Concentricity between mounting flange and shaft within .010.
2. Perpendicularity between mounting surface and shaft within .010.

Order Parts for Assembly No. FC308054 and FC308055

	Armature Hub	Armature Plate Assembly	Magnet Accessory	(1615) Taper Bushing	FC308054	FC308055	Magnet
					Mounting Plate with Accessory		
					Inside Mounted	Outside Mounted	
24 Volts	308680	308382-4	326078	326015-XX	308481	308491	308373
90 Volts	308680	308382-4	326078	326015-XX	308481	308491	308374

To order, specify: 1, Armature Hub 1, Armature Plate Assembly
 1, Magnet Accessory 1, Taper Bushing (1615) of required Bore size
 1, Mounting Plate with Accessory for either Inside Mount or Outside Mount
 1, Magnet of required Voltage

For controls, see Section K.

Flange Mounted Brake – Replacement Parts

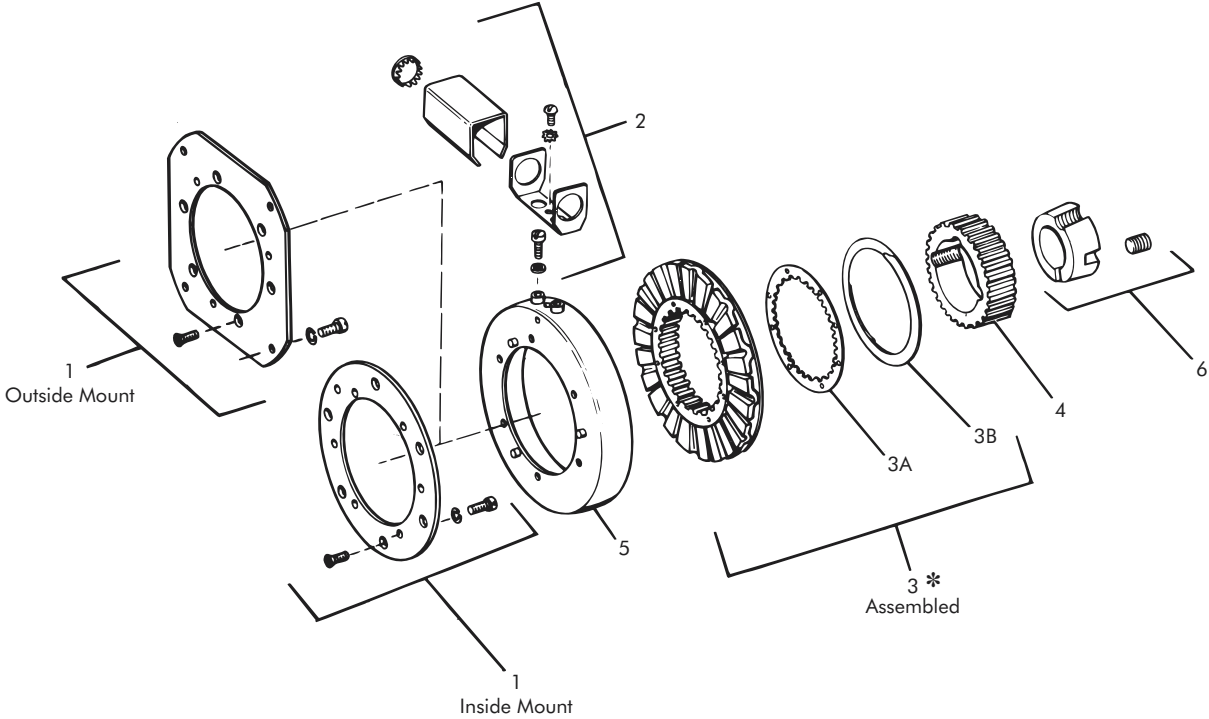

Replacement Parts

Item	Qty.	Description	Part No.	Item	Qty.	Description	Part No.
1	1	Mounting Plate w/Accessory Inside Mounting Outside Mounting	308481 308491	4	1	Armature Hub	308680
2	1	Magnet Accessory	326078	5	1	Magnet 24 Volts 90 Volts	308373 308374
3	1	Armature Plate Assy. (27 Teeth)	308382-4	6	1	Taper Bushing (1615)	326015-XX
3-A	3	Drag Spring	326276				
3-B	3	Ajusto-gap® Spring	326273				

* Current design armatures are solid.

Flange Mounted Brake

Model

● 310

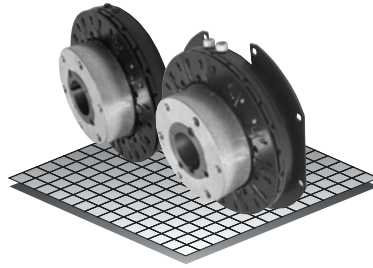

▶ Flange Mounted

▶ Pin Drive

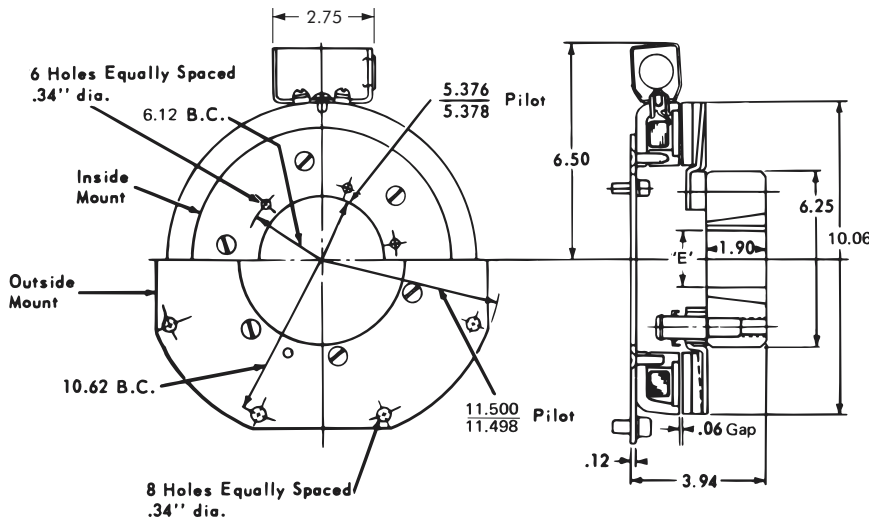

Bushing 2517

Bore 'E'	Keyway	Part No.
1/2"	.500 .125 x .062	326039 - 1
9/16"	.562 .125 x .062	326039 - 2
5/8"	.625 .187 x .093	326039 - 3
11/16"	.687 .187 x .093	326039 - 4
3/4"	.750 .187 x .093	326039 - 5
13/16"	.812 .187 x .093	326039 - 6
7/8"	.875 .187 x .093	326039 - 7
15/16"	.937 .250 x .125	326039 - 8
1"	1.000 .250 x .125	326039 - 9
1-1/16"	1.062 .250 x .125	326039 - 10
1-1/8"	1.125 .250 x .125	326039 - 11
1-3/16"	1.187 .250 x .125	326039 - 12
1-1/4"	1.250 .250 x .125	326039 - 13
1-5/16"	1.312 .312 x .156	326039 - 14
1-3/8"	1.375 .312 x .156	326039 - 15
1-7/16"	1.437 .375 x .187	326039 - 16
1-1/2"	1.500 .375 x .187	326039 - 17
1-9/16"	1.562 .375 x .187	326039 - 18
1-5/8"	1.625 .375 x .187	326039 - 19
1-11/16"	1.687 .375 x .187	326039 - 20
1-3/4"	1.750 .375 x .187	326039 - 21
1-13/16"	1.812 .500 x .250	326039 - 22
1-7/8"	1.875 .500 x .250	326039 - 23
1-15/16"	1.937 .500 x .250	326039 - 24
2"	2.000 .500 x .250	326039 - 25
2-1/16"	2.062 .500 x .250	326039 - 26
2-1/8"	2.125 .500 x .250	326039 - 27
2-3/16"	2.187 .500 x .250	326039 - 28
2-1/4"	2.250 .500 x .250	326039 - 29
2-5/16"	2.312 .625 x .187	326039 - 30
2-3/8"	2.375 .625 x .187	326039 - 31
2-7/16"	2.437 .625 x .187	326039 - 32
2-1/2"	2.500 .625 x .187	326039 - 33

Technical Data and Torque (In. Lb.)

Model No.	Wt. Lbs.	Static Torque in. lb.	Max. Speed RPM	Coil Voltage vdc	* Rated Current amps	RPM							
						0	300	600	900	1200	1500	1800	2400
310	26	3600	2400	90	.60	3600	3144	2616	2088	1788	1596	1416	1044

* Rated current at 90v.

Customer must maintain:

1. Concentricity between mounting flange and shaft within .010.

2. Perpendicularity between mounting surface and shaft within .010.

Refer to Section M for torque and heat dissipation curves.

Order Parts for Assembly No. FC310050 and FC310051

	Armature Hub	Armature Plate Assembly	Magnet Accessory	(2517) Taper Bushing	FC310050	FC310051	Magnet	Ajusto-gap® Accessory
					Mounting Plate with Access.			
					Inside Mounting	Outside Mounting		
24 Volts	310450	310380	326078	326039-XX	310481	310491	310373	326075
90 Volts	310450	310380	326078	326039-XX	310481	310491	310374	326075

To order, specify:

- 1, Armature Hub
- 1, Armature Plate Assembly
- 1, Magnet Accessory
- 1, Taper Bushing (2517) of required Bore size
- 1, Mounting Plate with Accessory for either Inside Mount or Outside Mount
- 1, Magnet of required Voltage
- 1, Ajusto-gap® Accessory

For controls, see Section K.

Flange Mounted Brake – Replacement Parts

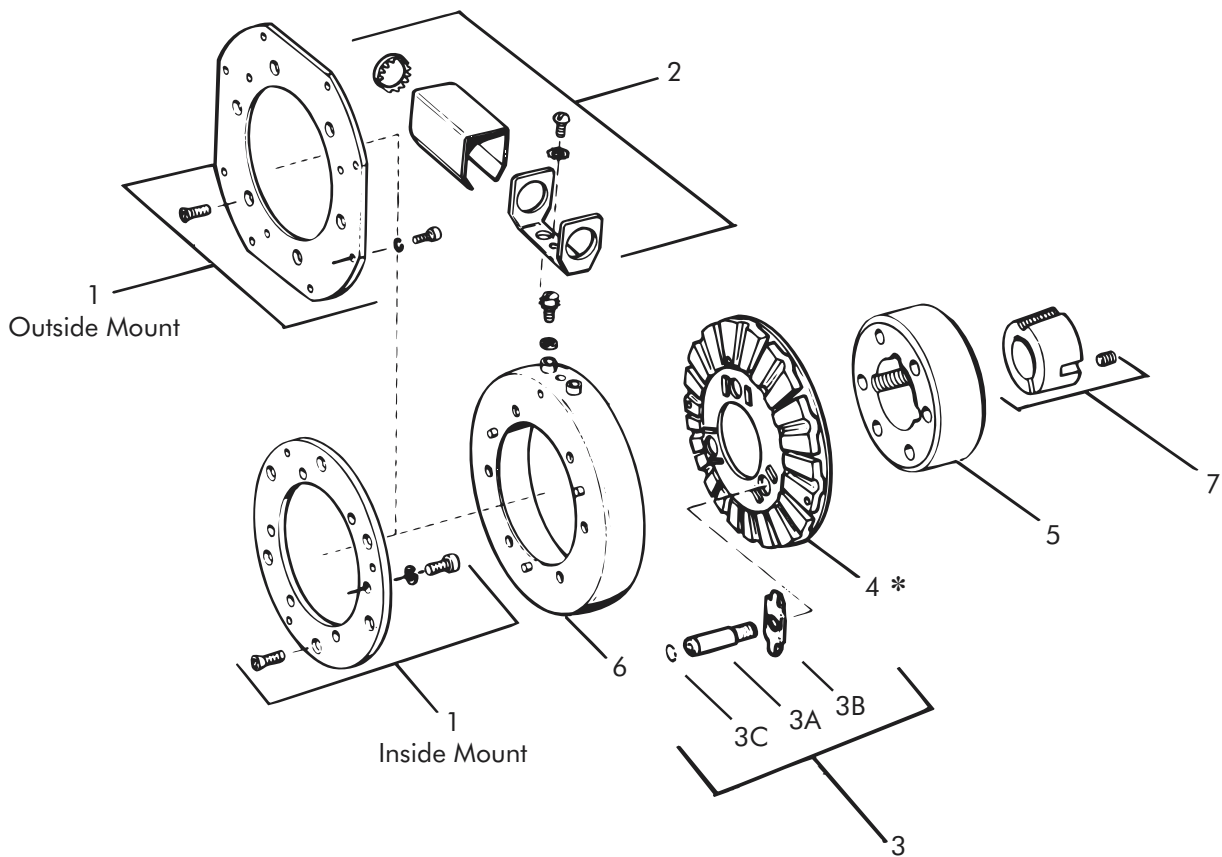

Replacement Parts

Item	Qty.	Description	Part No.	Item	Qty.	Description	Part No.
1	1	Mounting Plate w/Accessory Inside Mounting Outside Mounting	310481 310491	4	1	Armature Plate Assembly	310380
2	1	Magnet Accessory	326078	5	1	Armature Hub	310450
3	1	Ajusto-gap® Accessory	326075	6	1	Magnet 24 Volts	310373
3-A	3	Drive Pin	326008	7	1	90 Volts Taper Bushing (2517)	310374 326039-XX
3-B	3	Spring	326149				
3-C	3	Retaining Ring	DY-10572				

* Current design armatures are solid.

Flange Mounted Brake

Model

● 310

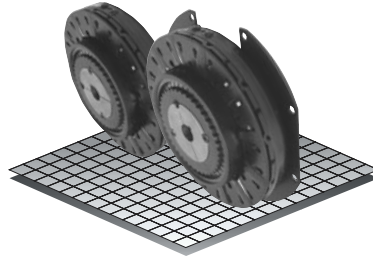

- ▶ Flange Mounted
- ▶ Spline Drive

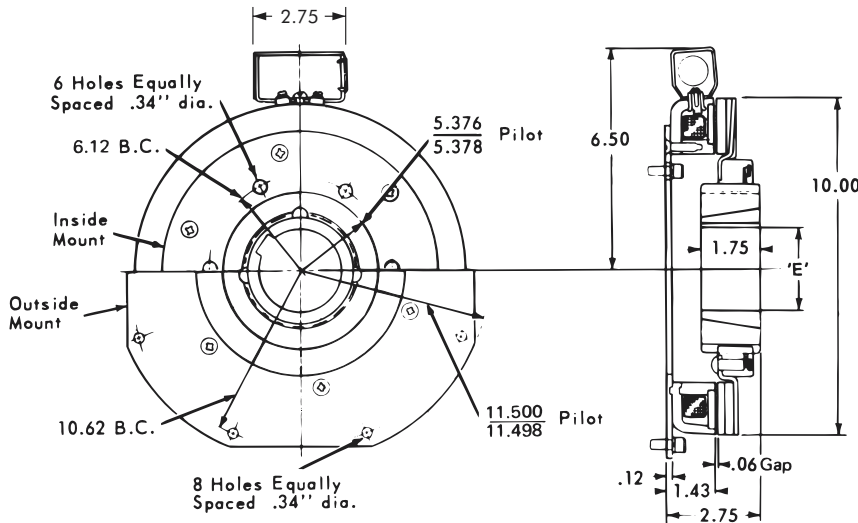

Bushing 2517

Bore 'E'		Keyway	Part No.
1/2"	.500	.125 x .062	326039 - 1
9/16"	.562	.125 x .062	326039 - 2
5/8"	.625	.187 x .093	326039 - 3
11/16"	.687	.187 x .093	326039 - 4
3/4"	.750	.187 x .093	326039 - 5
13/16"	.812	.187 x .093	326039 - 6
7/8"	.875	.187 x .093	326039 - 7
15/16"	.937	.250 x .125	326039 - 8
1"	1.000	.250 x .125	326039 - 9
1-1/16"	1.062	.250 x .125	326039 - 10
1-1/8"	1.125	.250 x .125	326039 - 11
1-3/16"	1.187	.250 x .125	326039 - 12
1-1/4"	1.250	.250 x .125	326039 - 13
1-5/16"	1.312	.312 x .156	326039 - 14
1-3/8"	1.375	.312 x .156	326039 - 15
1-7/16"	1.437	.375 x .187	326039 - 16
1-1/2"	1.500	.375 x .187	326039 - 17
1-9/16"	1.562	.375 x .187	326039 - 18
1-5/8"	1.625	.375 x .187	326039 - 19
1-11/16"	1.687	.375 x .187	326039 - 20
1-3/4"	1.750	.375 x .187	326039 - 21
1-13/16"	1.812	.500 x .250	326039 - 22
1-7/8"	1.875	.500 x .250	326039 - 23
1-15/16"	1.937	.500 x .250	326039 - 24
2"	2.000	.500 x .250	326039 - 25
2-1/16"	2.062	.500 x .250	326039 - 26
2-1/8"	2.125	.500 x .250	326039 - 27
2-3/16"	2.187	.500 x .250	326039 - 28
2-1/4"	2.250	.500 x .250	326039 - 29
2-5/16"	2.312	.625 x .187	326039 - 30
2-3/8"	2.375	.625 x .187	326039 - 31
2-7/16"	2.437	.625 x .187	326039 - 32
2-1/2"	2.500	.625 x .187	326039 - 33

Technical Data and Torque (In. Lb.)

Model No.	Wt. Lbs.	Static Torque in. lb.	Max. Speed RPM	Coil Voltage vdc	* Rated Current amps	RPM							
						0	300	600	900	1200	1500	1800	2400
310	25.1	3600	2400	90	.60	3600	3144	2616	2088	1788	1596	1416	1044

* Rated current at 90v.

Customer must maintain:

1. Concentricity between mounting flange and shaft within .010.
2. Perpendicularity between mounting surface and shaft within .010.

Refer to Section M for torque and heat dissipation curves.

Order Parts for Assembly No. FC310054 and FC310055

	Armature Hub	Armature Plate Assembly	Magnet Accessory	(2517) Taper Bushing	FC310054	FC310055	Magnet
					Mounting Plate with Accessory		
					Inside Mounted	Outside Mounted	
24 Volts	310680	310383-13	326078	326039-XX	310481	310491	310373
90 Volts	310680	310383-13	326078	326039-XX	310481	310491	310374

To order, specify:

- 1, Armature Hub
- 1, Armature Plate Assembly
- 1, Magnet Accessory
- 1, Taper Bushing (2517) of required Bore size
- 1, Mounting Plate with Accessory for either Inside Mount or Outside Mount
- 1, Magnet of required Voltage

For controls, see Section K.

Flange Mounted Brake – Replacement Parts

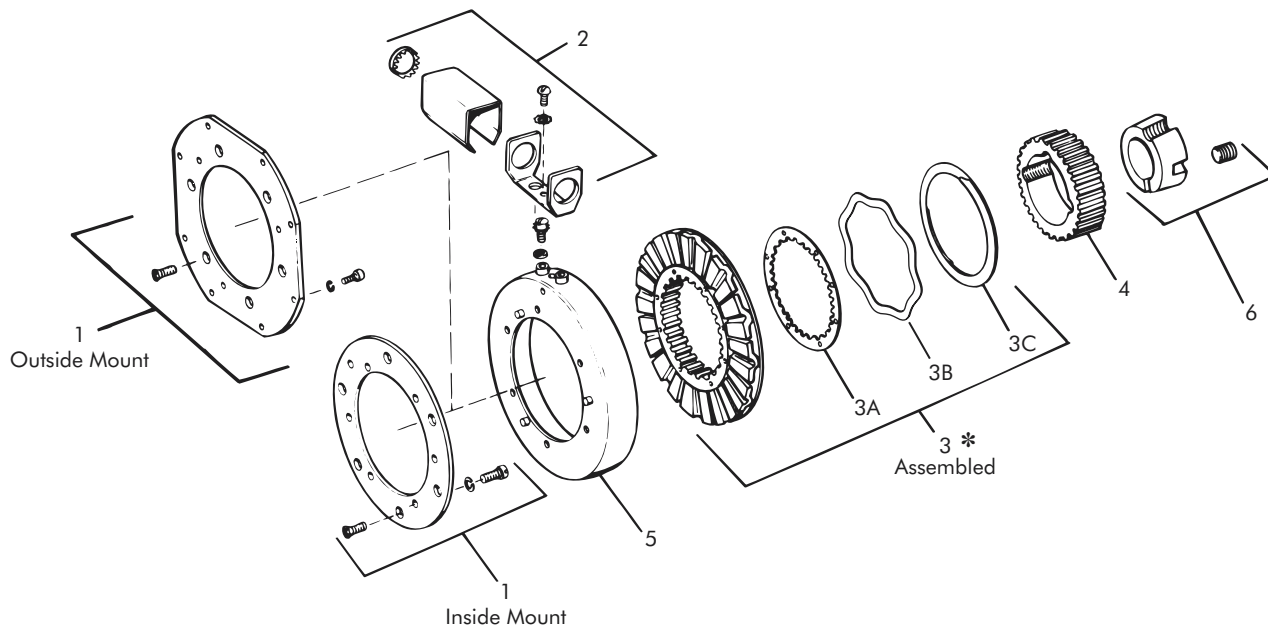

Replacement Parts

Item	Qty.	Description	Part No.	Item	Qty.	Description	Part No.
1	1	Mounting Plate w/Accessory Inside Mounting Outside Mounting	310481 310491	4	1	Armature Hub	310680
2	1	Magnet Accessory	326078	5	1	Magnet 24 Volts 90 Volts	310373 310374
3	1	Armature Plate Assy. (39 Teeth)	310383-13	6	1	Taper Bushing (2517)	326039-XX
3-A	1	Drag Spring	326277				
3-B	1	Ajusto-gap® Spring	326970				
3-C	1	Retaining Ring	RY-20317				

* Current design armatures are solid.

Ajusto-Gap® Armature and Hub Assembly

Used With

● 304

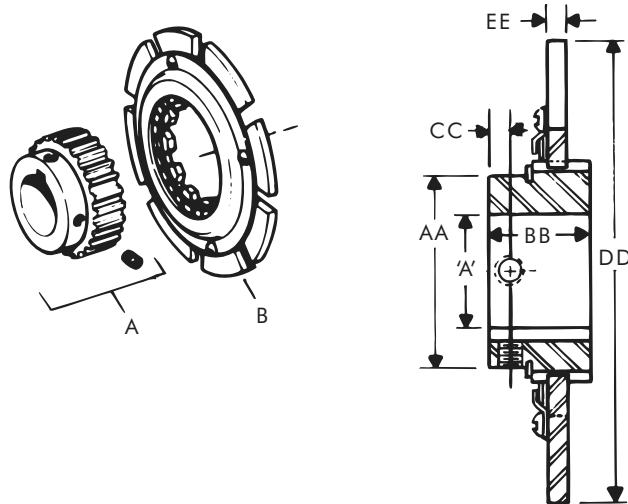

The Ajusto-gap® feature is used to give a positive release of the armature plate while maintaining a constant air gap throughout the wear life of the unit.

Armature Dimensions (Inches)

Part No.	AA	BB	CC	DD	EE
304396-8	-	-	-	4.00	16

Hub Dimensions (Inches)

304465	1.50	.86	.20	-	-
--------	------	-----	-----	---	---

Bore "A"	Keyway
7/8"	.187 x .094
1"	.250 x .125

.875 and 1.000 Bores

Item	Description	Part No.
A	Hub Assembly (Model 304)	
	7/8" Bore	304465-4
	1" Bore	304465-5
B	Armature Plate Assembly (Model 304) For Clutch Couplings and Brakes	304396-8

All the above armature plates can be used only with hubs as specified.

Terminal Insulating Kit

Used With

● 305 through 310

The terminal insulating kit is used in environments where it is either desirable or necessary to protect terminal connectors.

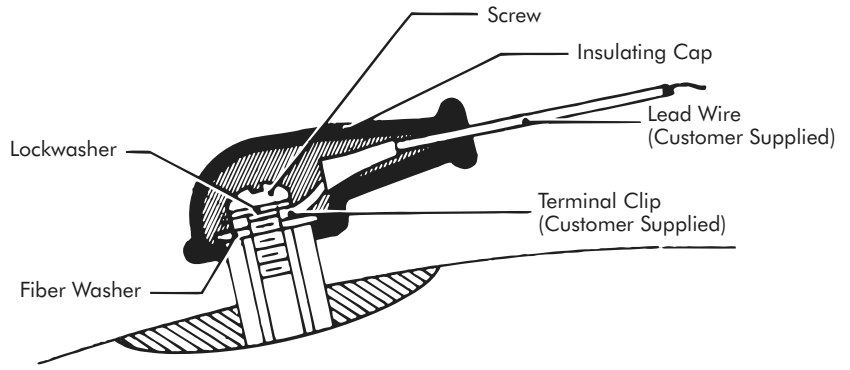

Model No.	Accessory Group
305 - 310	326297

Zero Air Gap Accessory Kit

Used With

- 305 through 310

The purpose of this kit is to hold the armature plate in contact with the friction face to reduce pull-in time. It is recommended where the engagement time is critical; usually high cycle rate applications with the D2950 control. Also use this kit when a slow start or stop is required with the D2750 control. Since the friction surfaces are always in contact a rubbing noise is created. The design of your machine may increase or decrease this noise.

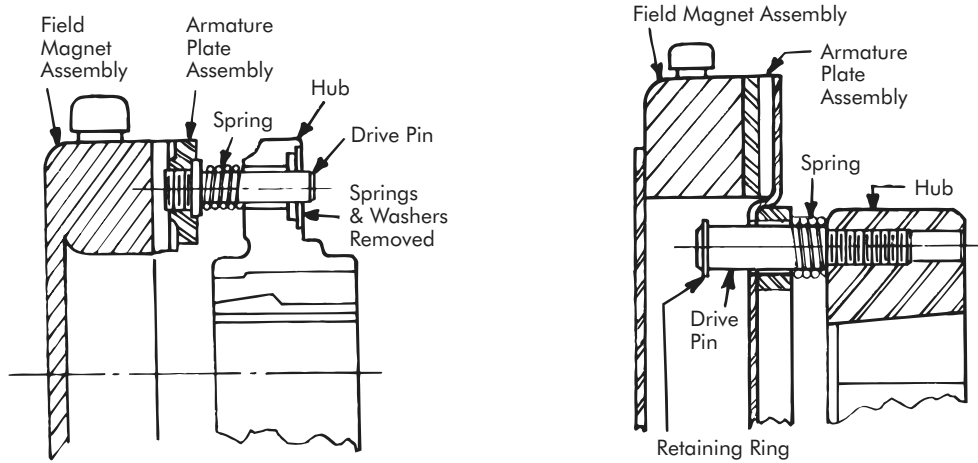

Model No.	Accessory Group
305	326303
308 - 310	326240