

# Dynatec® Controls

## Dynatec® 2950 Control

### Dual Channel Overexcite Clutch/Brake Control



#### Description

The Dynatec® 2950 (D2950) is a solid-state digital Overexcite (OE) clutch/brake controller, designed to operate 90 VDC clutch/brake (C/B) coils with current loads of up to 1.0 amp; Din rail mounting for ease of installation.

This controller operates one or two C/B coils with an adjustable anti-overlap circuit and OE.

The D2950 incorporates voltage protection on the AC input. When transient voltage spikes or notching is present on AC lines, an isolation transformer is required to filter the incoming power to the D2950.

#### Specifications

##### Power Input

Voltage: 115 VAC  
Current: 1.5 amp  
Frequency: 50/60 Hz  
Fusing: Customer-supplied 2 amp

##### Power Output

Voltage: 90 VDC (105 V actual)  
Overexcite Pulse: 325 VDC  
Current: 1.0 Max.

##### D2950 Dimensions

Weight: 17 Oz.  
Overall: 3.94" W. x 2.76" H. x 5.28" D.  
Mounting: Din rail

##### Temperature

Operating: 0° to 65°C (32° to 149°F)

#### Features

- Meets  Certification
- Adjustable clutch/brake "on" delay  
Anti-overlap potentiometer  
0 to 100 ms
- Status/Diagnostic lights:  
Clutch On  
Brake On
- Selective input switching logic  
Cold contact, 3 - 30 VDC or 115 VAC
- Outputs (2) 1 amp Max load
- Use with all Dynacorp® 90 V products, except 308HQ, 310HQ, and 312HQ models.

Input Logic	Part No.
115 VAC, 50/60 Hz	214277-040-2211
3-30 VDC	214277-040-2212
Contact Closure	214277-040-2213

### D2950 Overexcite

Overexcite produces a 270 VDC spike to the clutch or brake. This graph displays RPM curve of clutch brake package with No Overexcite.

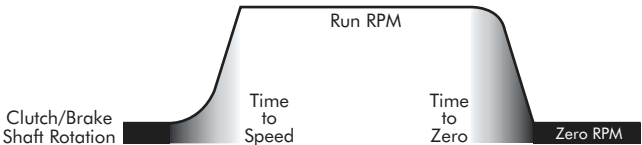

Clutch/Brake Shaft RPM Curve using Conventional Control

The Dynatec® 2950 incorporates an Overexcite feature. The results of Overexcite are displayed in the graph. The clutch and brake coils are saturated much faster, allowing for quick positive engagement, producing higher start/stop accuracy, while reducing friction heat.

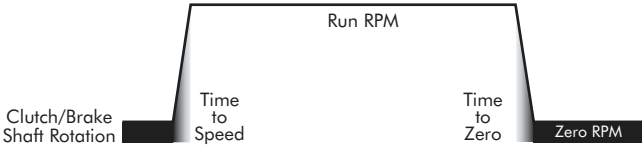

Clutch/Brake Shaft RPM Curve using Dynacorp® Control with Overexcite

### D2950 Anti-Overlap

When using conventional controls where the output voltage is switched by a relay contact, overlap occurs when you see the arching across the contacts. This indicates that just for an instant the brake and clutch are both engaged. This graph represents overlap. The effect of this is excessive wear and heat to the clutch/brake system.

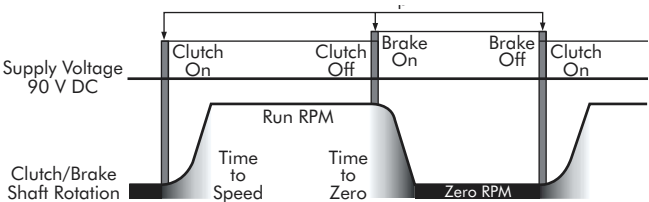

Clutch/Brake Shaft RPM Curve using Conventional Control

The Dynatec® 2950 incorporates MOV's and an adjustable time delay logic that will prevent the effects of overlap. This graph illustrates the effects of anti-overlap. Notice the difference between the RPM curves. You have a shorter time to speed and time to zero, and the switching is more precise, creating less heat. These controls can actually operate the clutch/brake system at higher cycle rates, with better repeatability and less heat than conventional controls.

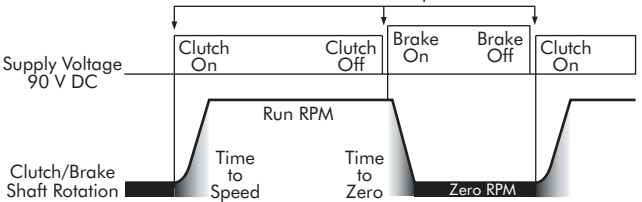

Clutch/Brake Shaft RPM Curve using Dynacorp® Control with Anti-Overlap

### D2950 Wiring Information

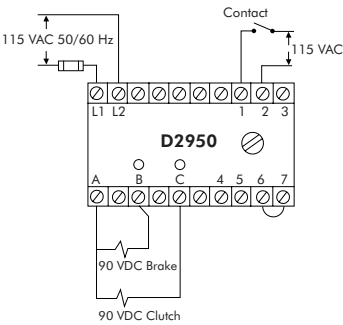

Wiring example for logic input 115 VAC

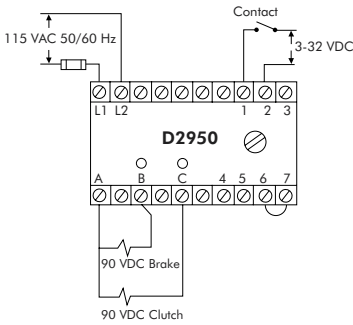

Wiring example for logic input 3-32 VDC

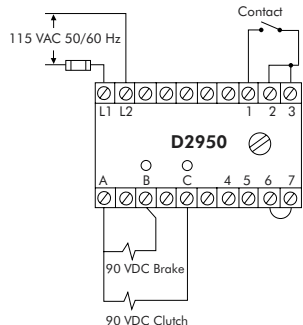

Wiring example for contact closure

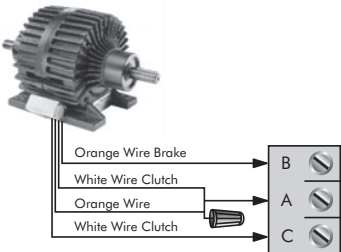

Dynacorp® Clutch/Brake Package Wiring

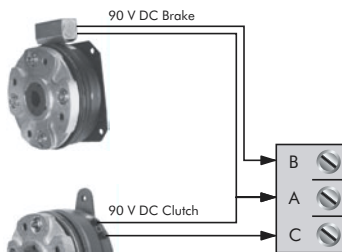

Single Clutch and Brake Wiring