

# Clutch Coupling

Model

● 303

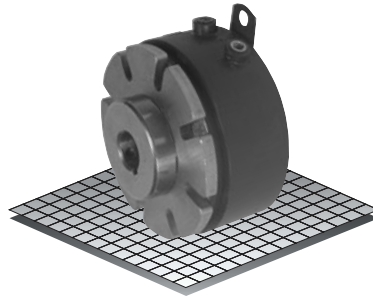

- ▶ Stationary Field
- ▶ Bearing Mounted
- ▶ Spline Drive

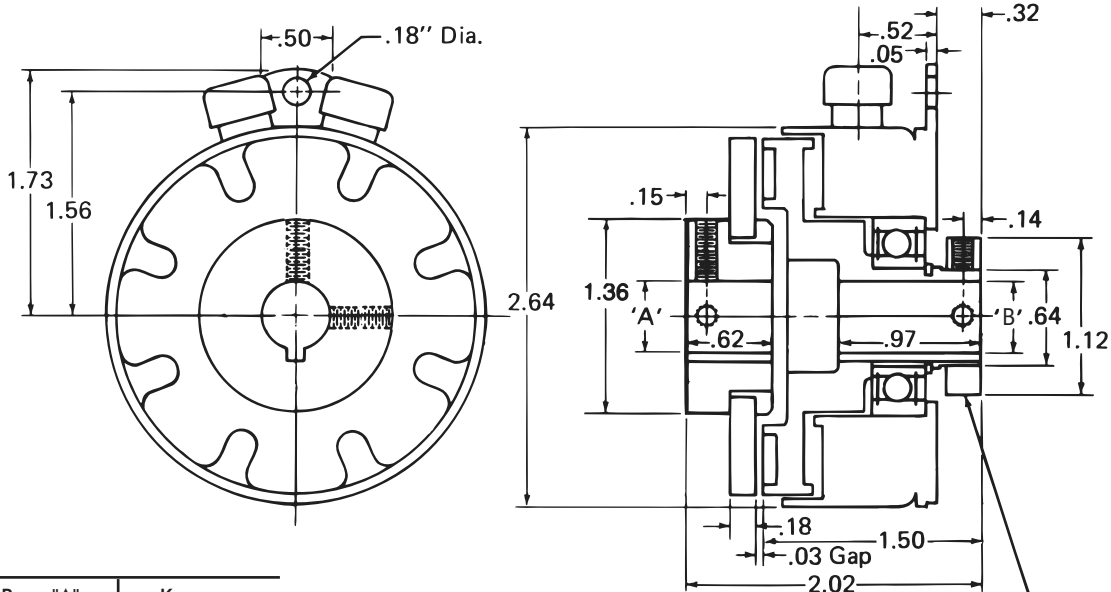

Collar used with 1/2" Rotor Bore only.

Bore "A"	Keyway
1/2"	.125 x .062
5/8"	.187 x .094
3/4"	.187 x .094

Bore "B"	Keyway
3/8"	.093 x .046
1/2"	.125 x .062

## Technical Data and Torque (In. Lb.)

Model No.	Wt. Lbs.	Static Torque in. lb.	Max. Speed RPM	Coil Voltage vdc	* Rated Current amps	RPM									
						0	300	600	900	1200	1500	1800	2400	3000	3600
303	1.3	60	3600	90	.11	60	53	48	43	42	41	38	34	32	30

\* Rated Current for 90v.  
Refer to Section M for torque and heat dissipation curves.

## Order Parts for Assembly No. FC303158

	Armature Plate Assembly	Magnet Accessory	Armature Hub Assembly			Bearing Mounted Rotor & Field	
			Bore "A"			Bore "B"	
			1/2"	5/8"	3/4"	3/8"	1/2"
24 Volts	303390-2	326147	303451-3	303451-5	303453-8	303773-1	303773-3
90 Volts	303390-2	326147	303451-3	303451-5	303453-8	303774-1	303774-3

To order, specify: 1, Armature Plate Assembly  
1, Magnet Accessory  
1, Armature Hub Assembly of required Bore "A" size  
1, Bearing Mounted Rotor and Field Assembly of required Voltage and Bore "B" size

For controls, see Section K.

# Clutch Coupling – Replacement Parts

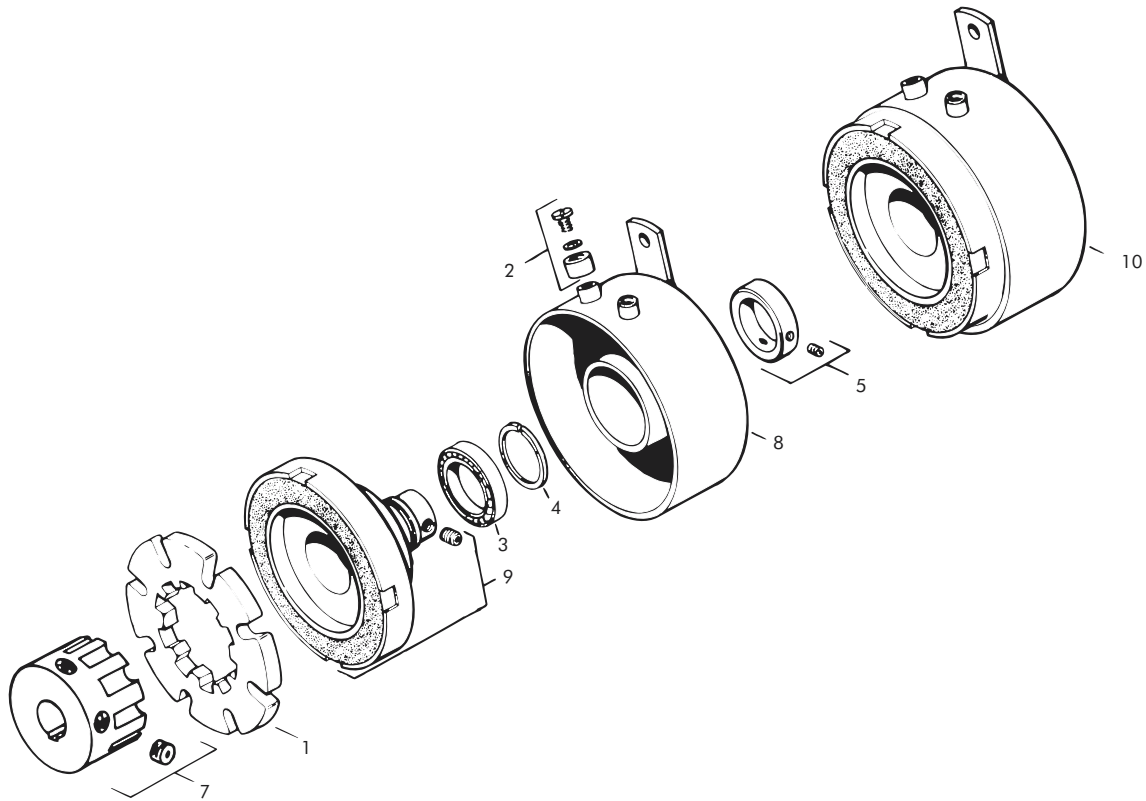

## Replacement Parts

Item	Qty.	Description	Part No.	Item	Qty.	Description	Part No.
1	1	Armature Plate Assembly (10 Teeth)	303390-2	9	1	Rotor Assembly	
2	1	Magnet Accessory	326147			3/8" Bore	303556-1
3	1	Bearing	DY-9436			1/2" Bore	303556-3
4	1	Retaining Ring (External)	DY-1581	10	1	Bearing Mounted Rotor and	
5	1	Collar (furnished with .500 bore)	326304-1			Field Assembly	
7	1	Armature Hub Assembly				24 Volts, 3/8" Bore	303773-1
		3/8" Bore (plain bore)	303453-PB			24 Volts, 1/2" Bore	303773-3
		1/2" Bore	303451-3			90 Volts, 3/8" Bore	303774-1
		5/8" Bore	303451-5			90 Volts, 1/2" Bore	303774-3
		3/4" Bore	303453-8				
8	1	Field					
		24 Volts	303333				
		90 Volts	303334				