

Hub Pin Hole Mounting Dimensions

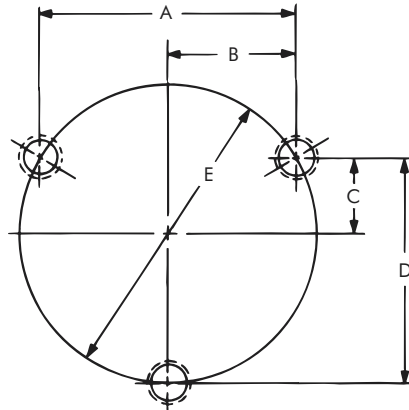

3 Pin Mounting
Models 308 and 310

Drive Pin Hole Mounting Dimensions (Inches)

Model No.	A	B	C	D	E	No. of Pins
308	3.085 / 3.087	1.542 / 1.544	.890 / .892	2.671 / 2.673	3.562 / 3.564	3
310	4.547 / 4.549	2.273 / 2.275	1.312 / 1.314	3.938 / 3.940	5.250 / 5.254	3

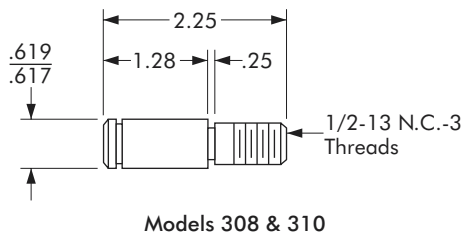

Models 308 & 310

NOTE:

Chordal dimensions must be held for all chords between pin holes. Pins must be square with the plane of the mounting surface and magnet mounting.

Drill .422 inch diameter hole to a sufficient depth for 1/2-13 NC-3 x 1 inch minimum full thread. Ream .500/.501 inch to .375 inch depth. Ream to concentric with tap.

Terminal Insulating Kit

Used With

● 305 through 310

The terminal insulating kit is used in environments where it is either desirable or necessary to protect terminal connectors.

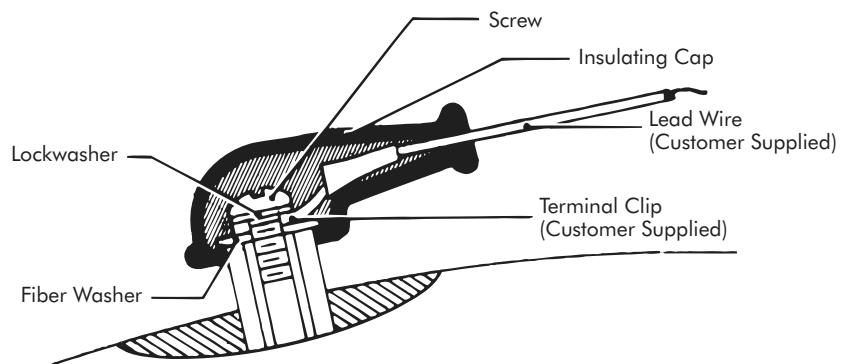

Model No.	Accessory Group
305 - 310	326297