

Shaft Input Modules

Open Drip Proof

Models

- CBP-184-125-SI
- CBP-184-125-SIB

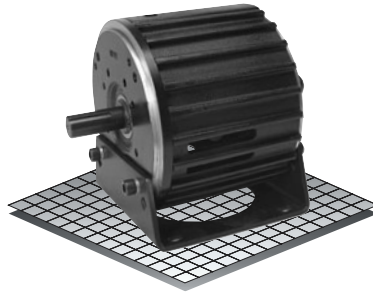

- ▶ Factory Assembled and Tested
- ▶ Spline Drive
- ▶ Shaft Input
- ▶ Mounting Base (SIB)

Clutch-Brake Module

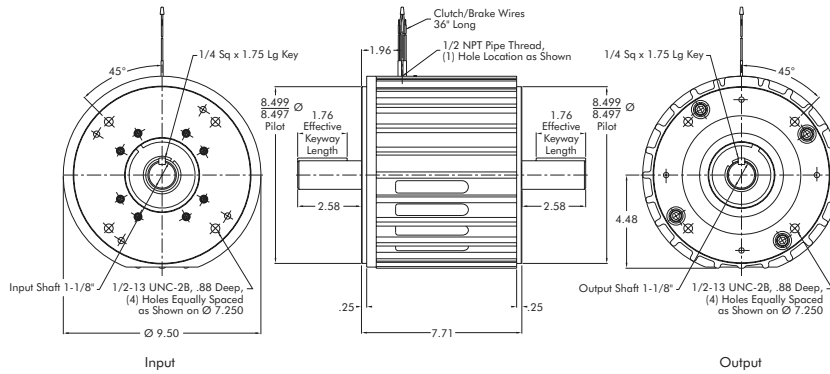

Clutch-Brake Module

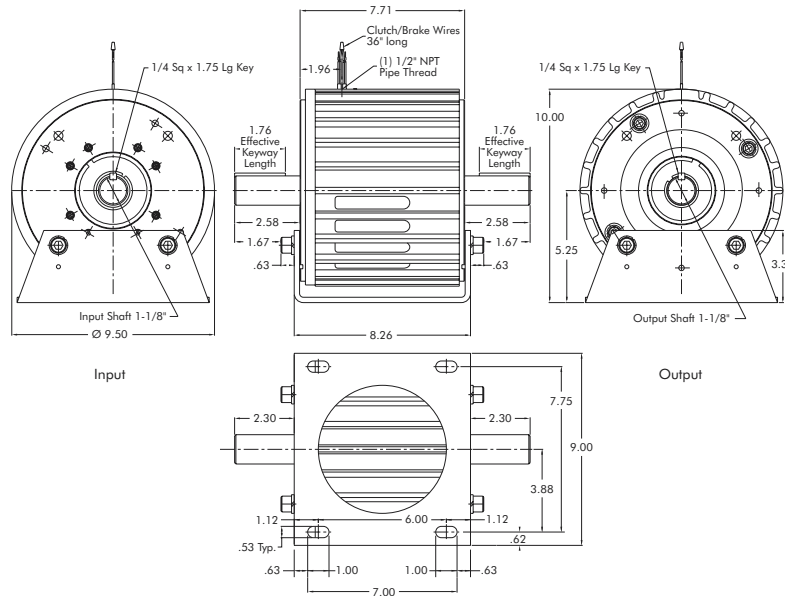

Technical Data and Torque (In. Lb.)

Model No.	Wt. Lbs.	Static Torque in. lb.	Max. Speed RPM	Coil Voltage vdc	* Rated Current amps	RPM									
						0	300	600	900	1200	1500	1800	2400	3000	3600
CBP-184-125-SI	49	1500	3600	90	.46	1500	1320	1140	1020	960	900	804	636	516	420
CBP-184-125-SIB	49					1500	1320	1140	1020	960	900	804	636	516	420

* Rated Current for 90v

Refer to Section M for torque and heat dissipation curves.

	SI Module No.	SIB Module No.
	CBP-184-125-SI	CBP-184-125-SIB
24 Volt	307194-42	307194-50
90 Volt	307194-43	307194-51

To order use number shown in table above: example – for 90 Volt CBP-184-125-SIB, order 307194-51. For controls, see Section K.

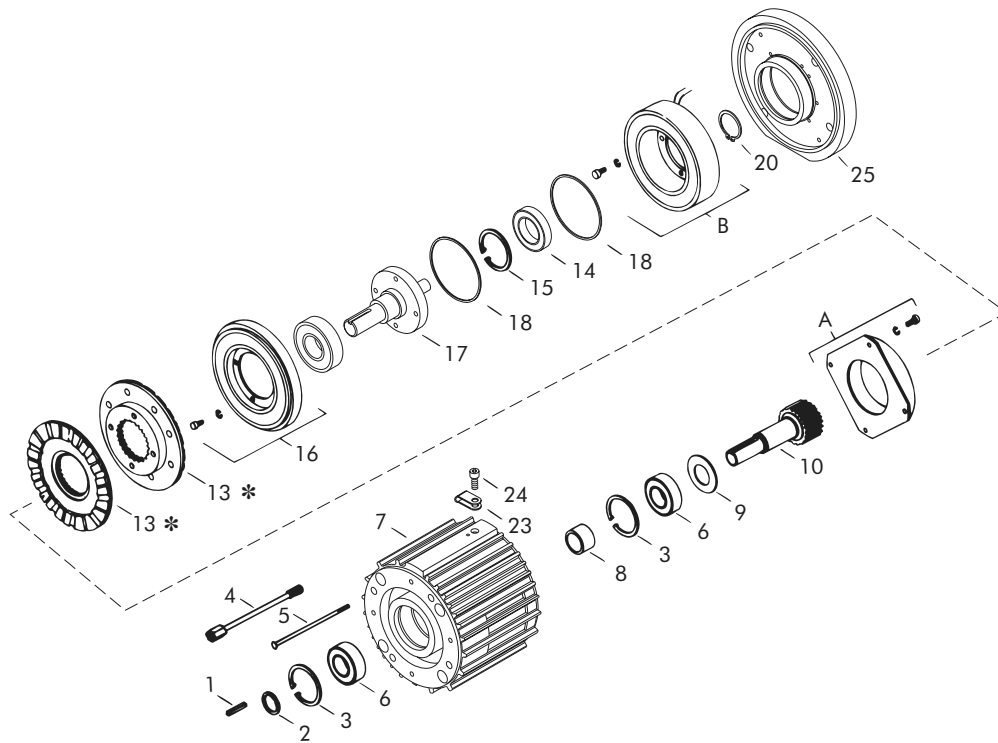

Replacement Parts

Item	Qty.	Description	Model No.	
			Clutch-Brake Module	Clutch-Brake Module
			CBP-184-125-SI	CBP-184-125-SIB
1	2	Input/Output Key	326770	326770
2	1	Retaining Ring	RY-20191	RY-20191
3	2	Retaining Ring	RY-20114	RY-20114
4	4	Cap Screw	RY-20380	RY-20380
5	4	Lock Washer (not shown)	DY-4771	DY-4771
6	2	Bearing	RY-20115	RY-20115
7	1	Housing	650377-2	650377-2
8	1	Bearing Spacer	326699	326699
9	1	Felt Washer	326769-2	326769-2
10	1	Output Shaft and Hub	650340-18	650340-18
11	8	Cap Screw (not shown)	DY-644	DY-644
12	8	Lock Washer (not shown)	DY-4498	DY-4498
13	2	Armature	307382-1	307382-1
14	1	Bearing	RY-20073	RY-20073
15	1	Retaining Ring	RY-20379	RY-20379
16	1	Rotor	307820-11	307820-11
17	1	Input Shaft and Hub	650340-16	650340-16
18	2	Retaining Ring	DY-11735	DY-11735
19	1	Bearing	DY-10228	DY-10228
20	1	Retaining Ring	RY-20017	RY-20017
21	8	Cap Screw (not shown)	RY-20276	RY-20276
22	8	Lock Washer (not shown)	101263	101263
23	1	Wire Clip	36-42-3	36-42-3
24	1	Cap Screw	DY-10278	DY-10278
25	1	Clutch End Cap	650380-2	650380-2
26	1	Base (SIB Only)	–	650363-7
30	4	Cap Screw	–	RY-20381
31	4	Lock Washer	–	DY-4473
A	1	Brake Field		
		24 Volt DC	307353-4	307353-4
		90 Volt DC	307354-4	307354-4
B	1	Clutch Field		
		24 Volt DC	307713-5	307713-5
		90 Volt DC	307714-5	307714-5

* Current design armatures are solid.