

# Shaft Input Modules

# Open Drip Proof

Models

- CBP-145-22-SI
- CBP-145-32-SI
- CBP-145-22-SIB
- CBP-145-32-SIB
- CP-145-32-SIB



- ▶ Factory Assembled and Tested
- ▶ Spline Drive
- ▶ Shaft Input
- ▶ Mounting Base (SIB)

## SI Clutch-Brake Module

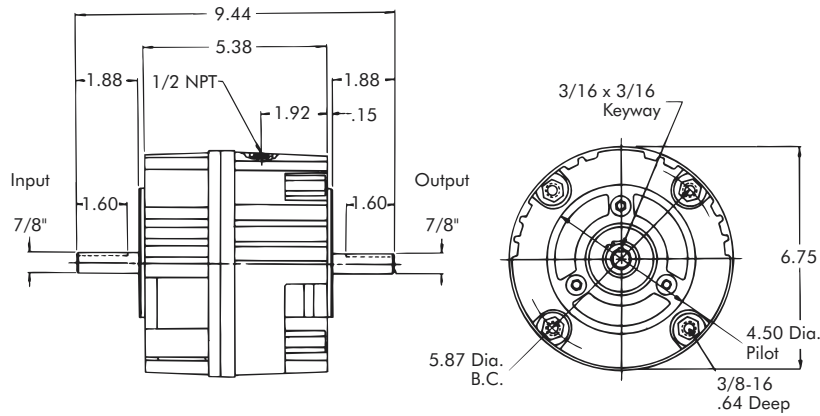

## SIB Clutch-Brake Module or Clutch Module

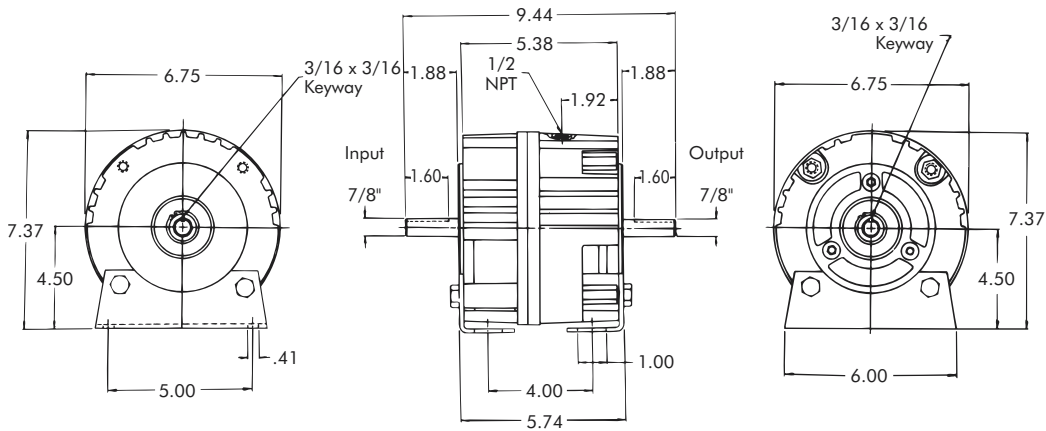

## Technical Data and Torque (In. Lb.)

Model No.	Wt. Lbs.	Static Torque in. lb.	Max. Speed RPM	Coil Voltage vdc	* Rated Current amps	RPM									
						0	300	600	900	1200	1500	1800	2400	3000	3600
CBP-145-22-SI	16	264	3600	90	.18	264	216	192	180	168	156	156	144	132	120
CBP-145-22-SIB	16														
CBP-145-32-SI	16	384	3600	90	.18	384	312	276	264	240	228	228	216	192	168
CBP-145-32-SIB	16														
CP-145-32-SIB	12														

\* Rated Current for 90v

Refer to Section M for torque and heat dissipation curves.

	SI Module No.		SIB Module No.		
	CBP-145-22-SI	CBP-145-32-SI	CBP-145-22-SIB	CBP-145-32-SIB	CP-145-32-SIB
24 V	304194-46	304294-46	304194-54	304294-54	-
90 V	304194-47	304294-47	304194-55	304294-55	304296-55

To order use number shown in table above: example – for 90 Volt CBP-145-22-SI, order 304194-47.

For controls, see Section K.

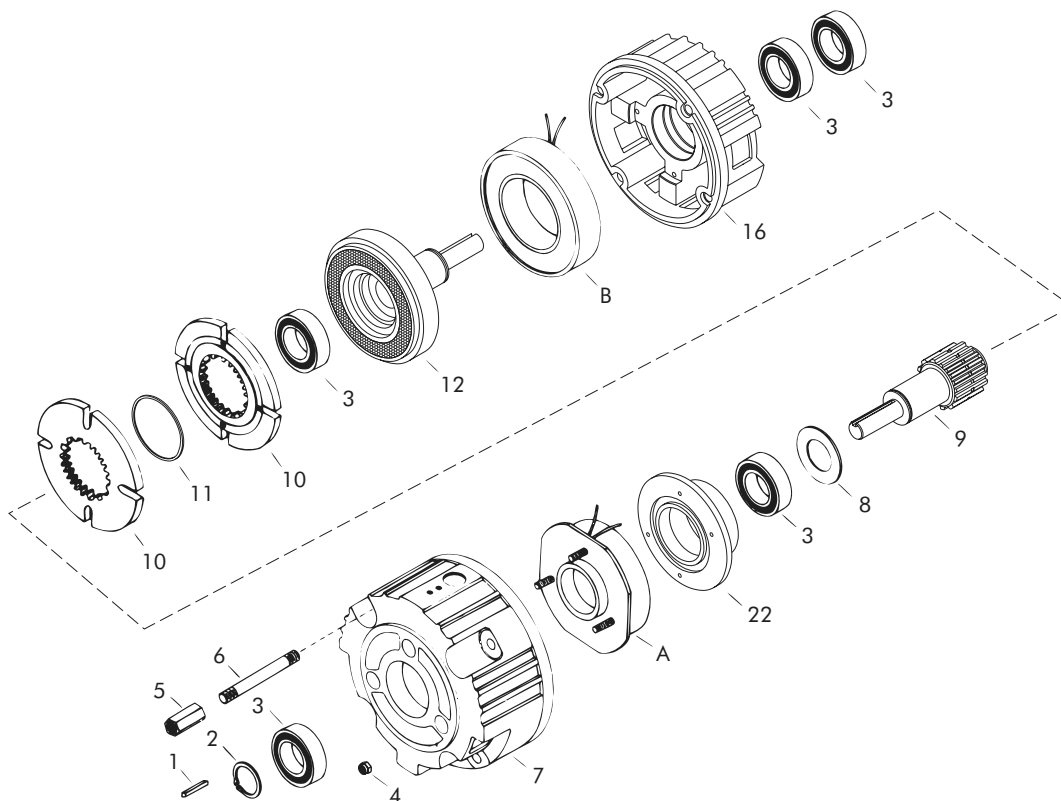

### Replacement Parts

Item	Qty.	Description	Model No.				
			Clutch-Brake Module				Clutch Module
			CBP-145-22-SI	CBP-145-32-SI	CBP-145-22-SIB	CBP-145-32-SIB	
1	2	Input/Output Key	DY-11212	DY-11212	DY-11212	DY-11212	DY-11212
2	2	Retaining Ring	DY-1102	DY-1102	DY-1102	DY-1102	DY-1102
3	4	Bearing	DY-11500	DY-11500	DY-11500	DY-11500	DY-11500
4	3	Locknut	RY-20113	RY-20113	RY-20113	RY-20113	RY-20113
5	4	Hex Nut	326850	326850	326850	326850	326850
6	4	Stud	326851-3	326851-3	326851-3	326851-3	326851-3
7	1	Brake End Bell	650337-3	650337-3	650337-3	650337-3	650337-3
8	1	Teflon Washer	326960	326960	326960	326960	326960
9	1	Output Shaft and Hub	650340-8	650340-8	650340-8	650340-8	650340-8
10	2 ●	Armature	304396-8	304396-8	304396-8	304396-8	304396-8
11	3	Retaining Ring	RY-20310	RY-20310	RY-20310	RY-20310	RY-20310
12	1	Input Shaft and Rotor	304528-6	304528-4	304528-6	304528-4	304528-4
13	2	Retaining Ring	DY-10860	DY-10860	DY-10860	DY-10860	DY-10860
16	1	Clutch End Bell	650389	650389	650389	650389	650389
17	3	Cap Screw	RY-20374	RY-20374	RY-20374	RY-20374	RY-20374
18	3	Lock Washer	DY-1548	DY-1548	DY-1548	DY-1548	DY-1548
19	2	Base (SIB Only)	–	–	650364-7	650364-7	650364-7
20	4	Cap Screw	–	–	DY-12710	DY-12710	DY-12710
21	4	Lock Washer	–	–	DY-4472	DY-4472	DY-4472
22	1	Bearing Support	–	–	–	–	304440-7
23	3	Button Screw	–	–	–	–	RY-20316
A	1	Brake Field					
		24 Volt DC	304353-14	304353-6	304353-14	304353-6	–
		90 Volt DC	304354-14	304354-6	304354-14	304354-6	–
B	1	Clutch Field					
		24 Volt DC	304333-11	304333-12	304333-11	304333-12	304333-12
		90 Volt DC	304334-11	304334-12	304334-11	304334-12	304334-12

● Qty. 1 on Clutch Module