

# Clutch-Brake Modules

# Enclosed Housing

Model

● CBP-215-125-E

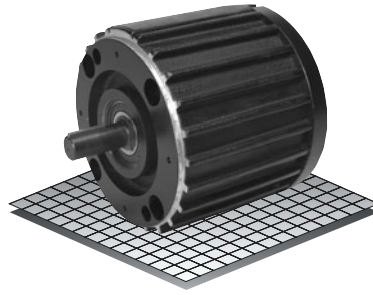

- ▶ Factory Assembled and Tested
- ▶ Spline Drive
- ▶ 213TC/215TC Flange

Clutch-Brake Module

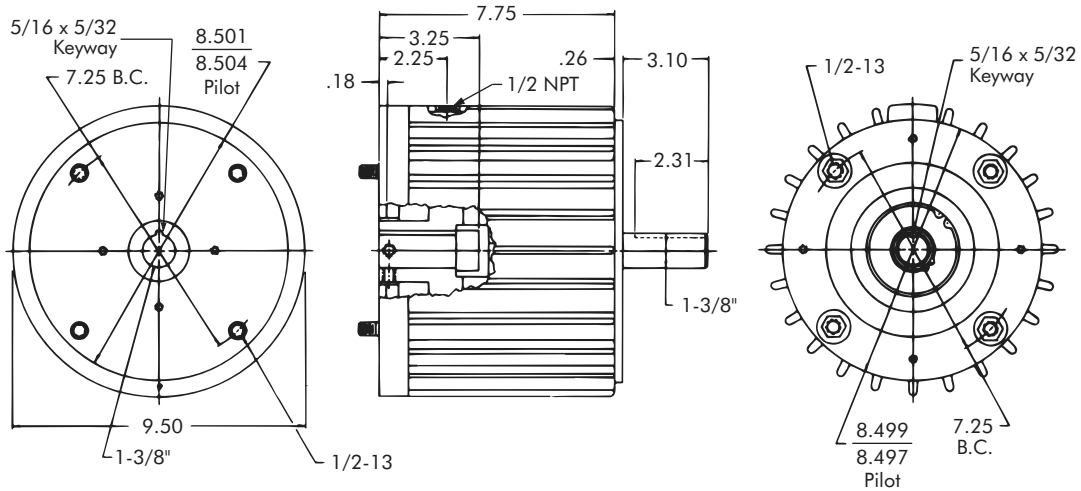

Technical Data and Torque (In. Lb.)

Model No.	Wt. Lbs.	Static Torque in. lb.	Max. Speed RPM	Coil Voltage vdc	* Rated Current amps	RPM									
						0	300	600	900	1200	1500	1800	2400	3000	3600
CBP-215-125-E	49	1500	3600	90	.46	1500	1320	1140	1020	960	900	804	636	516	420

Refer to Section M for torque and heat dissipation curves.

\* Rated Current for 90v

	Model No.
	CBP-215-125-E
24 Volts	307194-163
90 Volts	307194-164

To order use number shown in table above:  
example – for 90 volt CBP-215-125-E, order 307194-164.

For controls, see Section K.

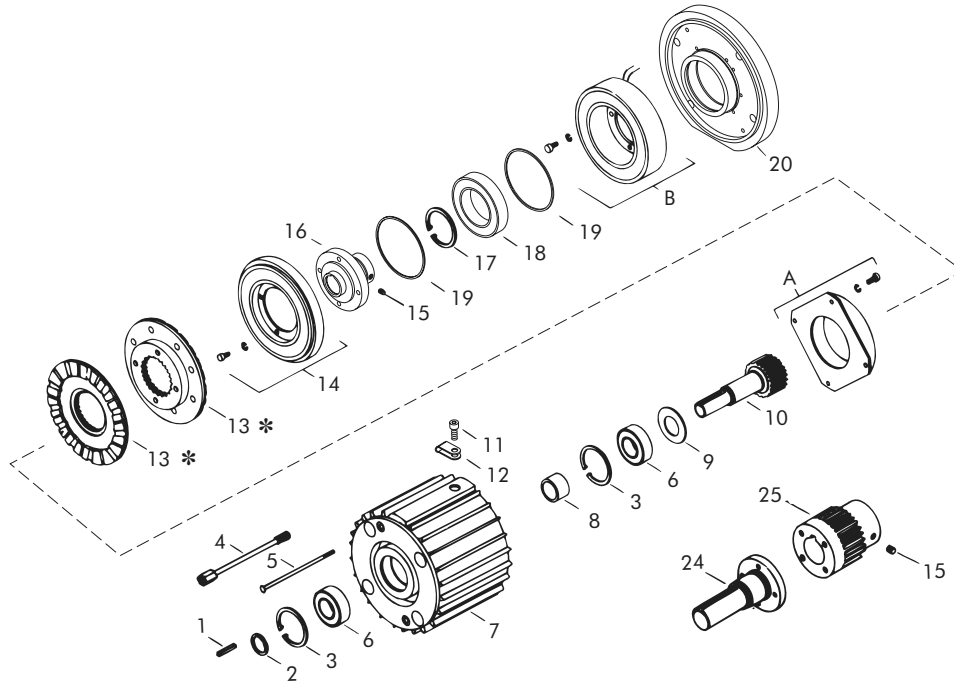

Replacement Parts

Item	Qty.	Description	Model No.
			Clutch-Brake Module
			CBP-215-125-E
1	2	Key	326771
2	1	Retaining Ring	RY-20191
3	1	Retaining Ring	RY-20114
4	4	Tie Bolt	650378
5	2	Assembly Screw	RY-20193
6	2	Bearing	RY-20115
7	1	Housing	650377-1
8	1	Bearing Spacer	326699
9	1	Washer	326769-2
10	1	Splined Shaft	650340-21
11	1	Cap Screw	DY-10278
12	1	Wire Clip	36-42-3
13	2	Armature	307382-1
14	1	Rotor	307820-11
15	2	Setscrew	–
16	1	Rotor Hub	307751-9
17	1	Retaining Ring	327064
18	1	Bearing	RY-20210
19	2	Retaining Ring	DY-15117
20	1	End Cap	650380-3
21	8	Screw	DY-644
22	12	Washer	DY-4498
23	6	Screw (not shown)	–
24	1	Brake Shaft	–
25	1	Brake Hub	–
26	1	Retaining Ring (not shown)	–
A	1	Brake Field	
		24 Volts	307353-4
		90 Volts	307354-4
B	1	Clutch Field	
		24 Volts	307713-5
		90 Volts	307714-5

\* Current design armatures are solid.