

# Clutch-Brake Modules

# Enclosed Housing

### Models

- CBP-145-22-E
- CBP-145-32-E
- BP-145-22-E
- BP-145-32-E

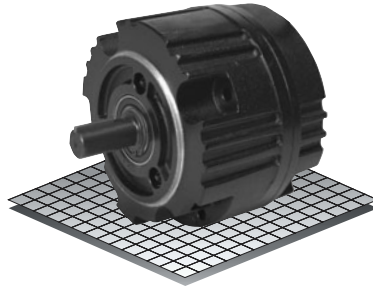

- ▶ Factory Assembled and Tested
- ▶ Spline Drive
- ▶ 143TC/143TC Flange

### Clutch-Brake Module

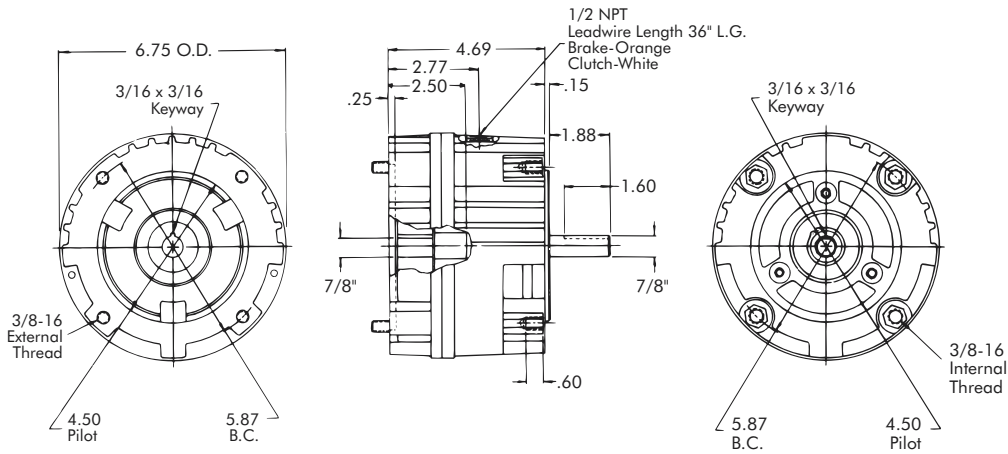

### Brake Module

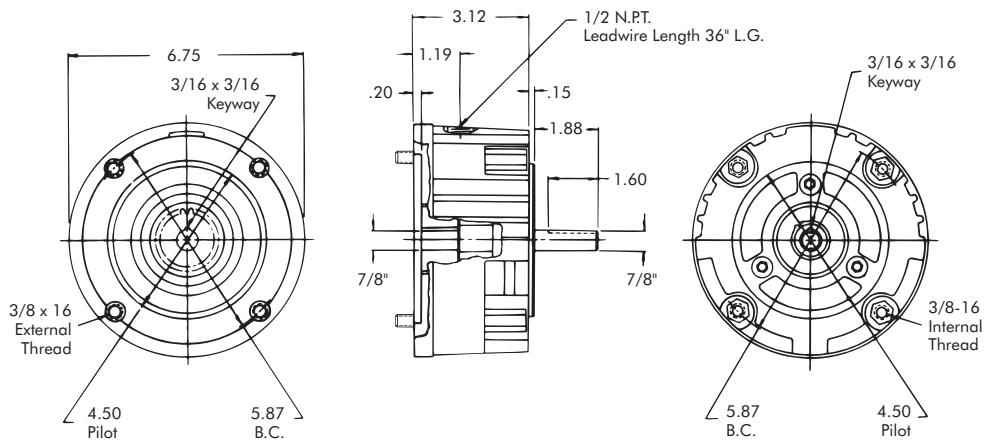

### Technical Data and Torque (In. Lb.)

Model No.	Wt. Lbs.	Static Torque in. lb.	Max. Speed RPM	Coil Voltage vdc	* Rated Current amps	RPM									
						0	300	600	900	1200	1500	1800	2400	3000	3600
CBP-145-22-E	16	264	3600	90	.18	264	216	192	180	168	156	156	144	132	120
BP-145-22-E	8														
CBP-145-32-E	16	384	3600	90	.18	384	312	276	264	240	228	228	216	192	168
BP-145-32-E	8														

\* Rated Current for 90v

Refer to Section M for torque and heat dissipation curves.

	Model No.			
	CBP-145-22-E	CBP-145-32-E	BP-145-22-E	BP-145-32-E
24 Volts	304194-93	304294-93	304195-93	304295-93
90 Volts	304194-94	304294-94	304195-94	304295-94

To order use number shown in table above: example – for 90 volt CBP-145-22-E, order 304194-94. For controls, see Section K.

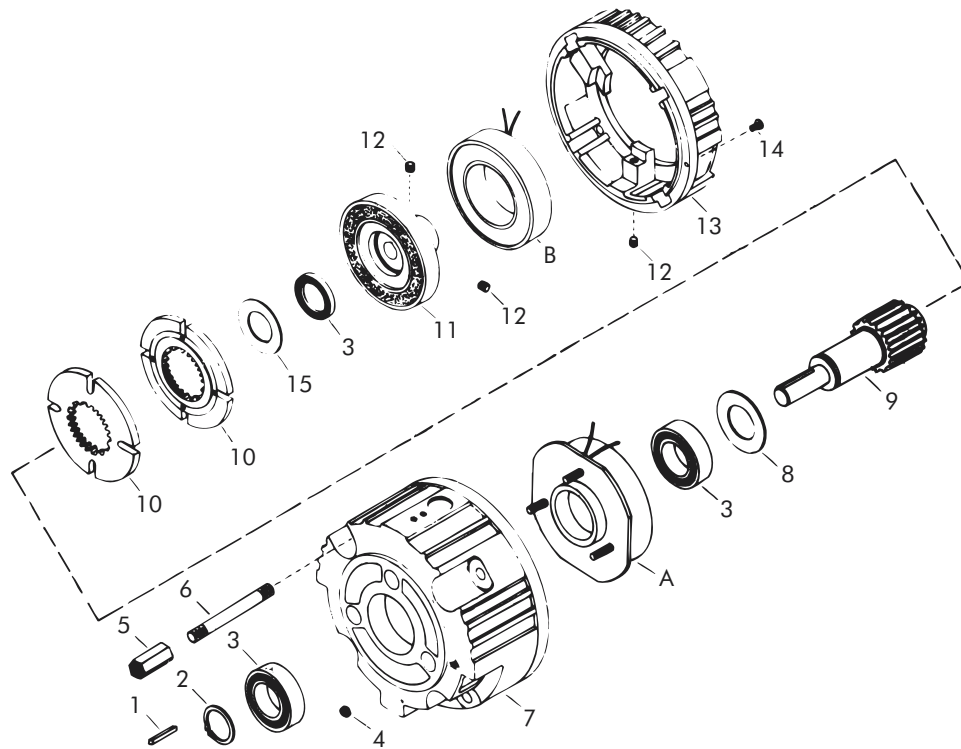

Replacement Parts

Item	Qty.	Description	Model No.			
			Clutch-Brake Module		Brake Module	
			CBP-145-22-E	CBP-145-32-E	BP-145-22-E	BP-145-32-E
1	1	Output Key	DY-11212	DY-11212	DY-6529	DY-6529
2	1	Retaining Ring	DY-1102	DY-1102	DY-1102	DY-1102
3	3 ●	Bearing	DY-11500	DY-11500	DY-11500	DY-11500
4	3	Nut	RY-20113	RY-20113	RY-20113	RY-20113
5	4	Hex Nut	326850	326850	326850	326850
6	4	Stud	326851-4	326851-4	326851-3	326851-3
7	1	Brake End Bell	650337-7	650337-7	650337-4	650337-4
8	1	Washer	326960	326960	-	-
9	1	Brake Shaft	650340-8	650340-8	650376-2	650376-2
10	2 ▼	Armature	304396-8	304396-8	304396-8	304396-8
11	1	Rotor	304527-8	304527-13	-	-
12	2	Setscrew	RY-20020	RY-20020	RY-20020	RY-20020
13	1	Clutch End Bell	650356-6	650356-6	-	-
14	2	Screw	RY-20374	RY-20374	-	-
15	1	Washer (not shown)	326961	326961	-	-
17	3	Screw	-	-	-	-
18	1	Bearing Support (not shown)	-	-	-	-
19	3	Screw (not shown)	DY-9980	DY-9980	-	-
20	2	Washer (not shown)	DY-1548	DY-1548	-	-
21	2 ▼	Retaining Ring (not shown)	RY-20310	RY-20310	RY-20310	RY-20310
A	1	Brake Field				
		24 Volts	304353-6	304353-11	304353-6	304353-11
		90 Volts	304354-6	304354-11	304354-6	304354-11
B	1	Clutch Field				
		24 Volts	304333-11	304333-12	-	-
		90 Volts	304334-11	304334-12	-	-

● Qty. 1 on Brake Module  
 ▼ Qty. 1 on Brake Module or Clutch Module