

Clutch-Brake Coupling

Model

● 305

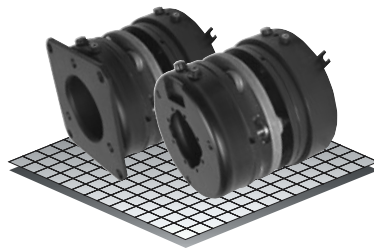

- ▶ Stationary Field
- ▶ Bearing Mounted
- ▶ Pin Drive

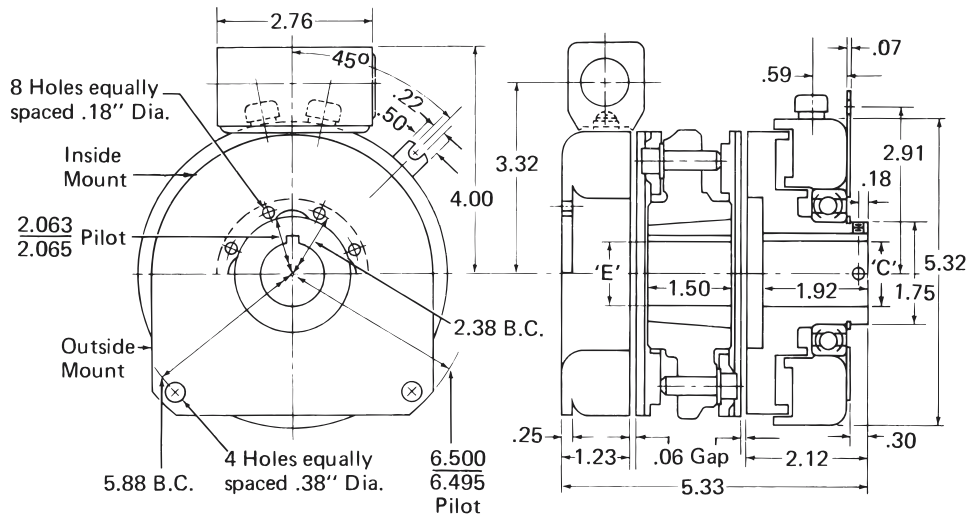

Bushing 1215

Bore "E"	Keyway	Part No.
1/2"	.500	.125 x .062 326058 - 1
9/16"	.562	.125 x .062 326058 - 2
5/8"	.625	.187 x .093 326058 - 3
11/16"	.687	.187 x .093 326058 - 4
3/4"	.750	.187 x .093 326058 - 5
13/16"	.812	.187 x .093 326058 - 6
7/8"	.875	.187 x .093 326058 - 7
15/16"	.937	.250 x .125 326058 - 8
1"	1.000	.250 x .125 326058 - 9
1-1/16"	1.062	.250 x .125 326058 - 10
1-1/8"	1.125	.250 x .125 326058 - 11
1-3/16"	1.187	.250 x .125 326058 - 12
1-1/4"	1.250	.250 x .125 326058 - 13

Technical Data and Torque (In. Lb.)

Model No.	Wt. Lbs.	Static Torque in. lb.	Max. Speed RPM	Coil Voltage vdc	* Rated Current amps	RPM									
						0	300	600	900	1200	1500	1800	2400	3000	3600
305	11.0	684	3600	90	.41	684	624	564	516	468	420	384	324	288	252

* Rated current at 90v.

Refer to Section M for torque and heat dissipation curves.

Customer must maintain:

1. Concentricity between mounting flange and shaft within .006.
2. Perpendicularity between mounting surface and shaft within .006.

Order Parts for Assembly No. FC305166 and FC305167

	Magnet Accessory	Armature Plate Assembly	Armature Hub Assembly	Bearing Mounted Rotor & Field (Clutch)					FC305166	FC305167	(1215) Taper Bushing
				Bore					Inside Mount	Outside Mount	
				3/4"	7/8"	1"	1-1/8"	1-1/4"			
24 Volts	326143	305381	305450	305773-1	305773-2	305773-4	305773-5	305773-6	305343	305353	326058-XX
90 Volts	326143	305381	305450	305774-1	305774-2	305774-4	305774-5	305774-6	305344	305354	326058-XX

To order, specify:

- 1, Magnet Accessory
- 2, Armature Plate Assemblies
- 1, Armature Hub Assembly
- 1, Magnet (Brake) of required Voltage for either Inside Mount or Outside Mount
- 1, Bearing Mounted Rotor & Field of required Bore size and Voltage
- 1, Taper Bushing (1215) of required Bore size

For controls, see Section K.

Clutch-Brake Coupling – Replacement Parts

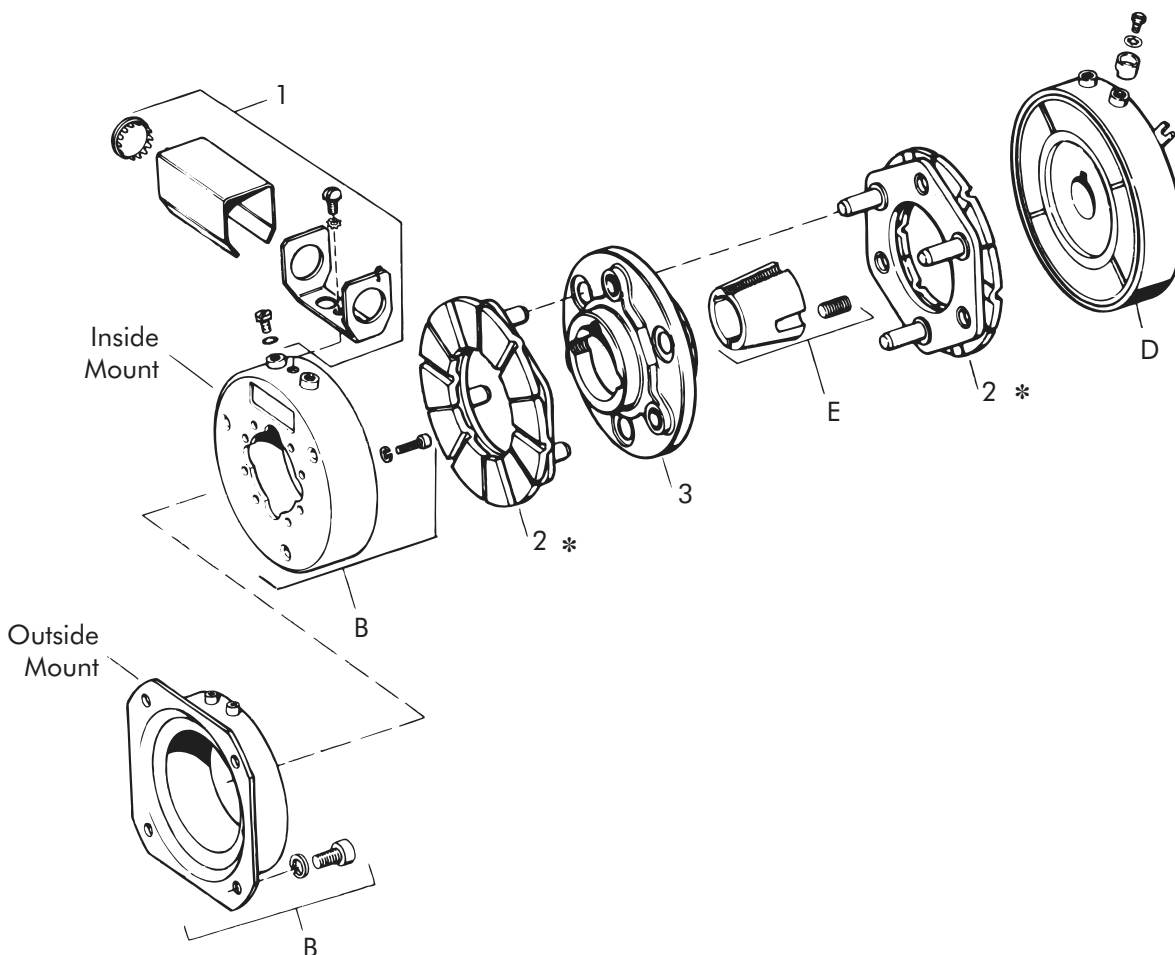

Replacement Parts

Item	Qty.	Description	Part No.	Item	Qty.	Description	Part No.
1	1	Magnet Accessories	326143	D	1	Bearing Mounted Rotor & Field	
2	2	Armature Plate	305381			24 Volts, 3/4" Bore	305773-1
3	1	Armature Hub Assembly	305450			24 Volts, 7/8" Bore	305773-2
B	1	Magnet (Brake)				24 Volts, 1" Bore	305773-4
		24 Volts, Inside Mount	305343			24 Volts, 1-1/8" Bore	305773-5
		90 Volts, Inside Mount	305344			24 Volts, 1-1/4" Bore	305773-6
		24 Volts, Outside Mount	305353			90 Volts, 3/4" Bore	305774-1
		90 Volts, Outside Mount	305354			90 Volts, 7/8" Bore	305774-2
						90 Volts, 1" Bore	305774-4
						90 Volts, 1-1/8" Bore	305774-5
						90 Volts, 1-1/4" Bore	305774-6
				E	1	Taper Bushing (1215)	326058-XX

* Current design armatures are solid.