

DC C-Face Coupler Brakes

M Series
 3 Ft-Lb
 6 Ft-Lb
 10 Ft-Lb

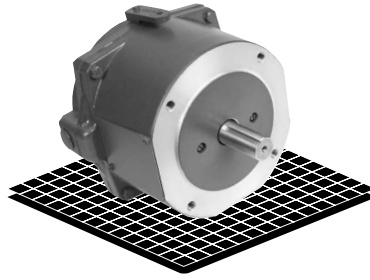

Nema 2 Housing

- Factory Assembled and Tested
- Manual Release
- DC Power Off
- C-Face 56C and 145TC
- Aluminum Head
- Aluminum Cover

C-Face Mounted Brake

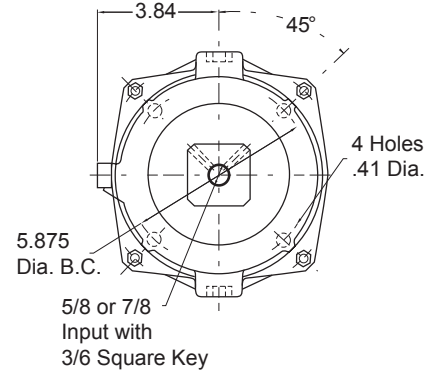
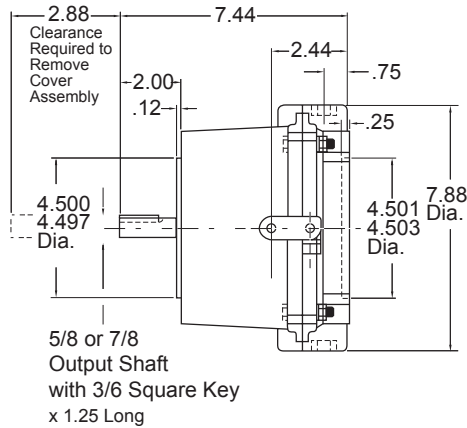
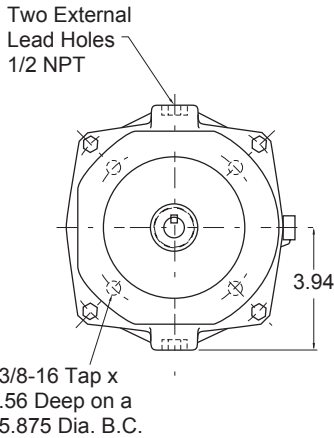

Average Ship Wt = 12.5Lbs

Brake Part Numbers

Coil Voltage	56C - 5/8 Bore Shaft and Hub		
	3 Ft. Lb. Brakes	6 Ft. Lb. Brakes	10 Ft. Lb. Brakes
24 VDC	M51A032Y	M52A062Y	M53A072Y
90 VDC	M51A032X	M52A062X	M53A072X

Coil Voltage	145TC - 7/8 Bore Shaft and Hub		
	3 Ft. Lb. Brakes	6 Ft. Lb. Brakes	10 Ft. Lb. Brakes
24 VDC	M51C032Y	M52C062Y	M53C072Y
90 VDC	M51C032X	M52C062X	M53C072X

Technical Data

DC Brake Coils		
Voltage	Current Amps	Resistance Ohms
24 VDC	.91	26.4
90 VDC	.25	365

Static Torque Ft. Lb.	Number Discs
3	1
6	2
10	3

Must be direct-coupled; mounted between motor and speed reducer.
 Not recommended for belted or other overhung load applications.